

DOT/FAA/AR-04/1

Office of Aviation Research
Washington, D.C. 20591

The Temperature Distribution Within Solid Metal Cylinders Subjected to a Standard Aircraft Engine Fire

John W. Reinhardt
Dung Do
Jason Fayer

April 2004

Data Report

This document is available to the U.S. public
through the National Technical Information
Service (NTIS), Springfield, Virginia 22161.



U.S. Department of Transportation
Federal Aviation Administration

NOTICE

This document is disseminated under the sponsorship of the U.S. Department of Transportation in the interest of information exchange. The United States Government assumes no liability for the contents or use thereof. The United States Government does not endorse products or manufacturers. Trade or manufacturer's names appear herein solely because they are considered essential to the objective of this report. This document does not constitute FAA certification policy. Consult your local FAA aircraft certification office as to its use.

This report is available at the Federal Aviation Administration William J. Hughes Technical Center's Full-Text Technical Reports page: actlibrary.tc.faa.gov in Adobe Acrobat portable document format (PDF).

1. Report No. DOT/FAA/AR-04/1		2. Government Accession No.		3. Recipient's Catalog No.	
4. Title and Subtitle THE TEMPERATURE DISTRIBUTION WITHIN SOLID METAL CYLINDERS SUBJECTED TO A STANDARD AIRCRAFT ENGINE FIRE				5. Report Date April 2004	
				6. Performing Organization Code	
7. Author(s) John W. Reinhardt, Dung Do, and Jason Fayer				8. Performing Organization Report No.	
9. Performing Organization Name and Address Federal Aviation Administration William J. Hughes Technical Center Airport and Aircraft Safety Research and Development Division Fire Safety Branch Atlantic City International Airport, NJ 08405				10. Work Unit No. (TRAIS)	
				11. Contract or Grant No.	
12. Sponsoring Agency Name and Address U.S. Department of Transportation Federal Aviation Administration Office of Aviation Research Washington, DC 20591				13. Type of Report and Period Covered Data Report	
				14. Sponsoring Agency Code	
15. Supplementary Notes					
16. Abstract This report provides temperature data that could be used to establish the ultimate tensile strength (UTS) loss of candidate engine mount materials after been exposed to a standard flame for 5 and 15 minutes. The materials tested included 4130 steel (baseline), 15-5 PH steel, titanium 6A1-4V, Inconel 718, and aluminum 7075. These materials were instrumented internally with thermocouples and exposed to the standard flame. MIL-Handbook-5H provides some data with regards to the UTS loss of these materials while heated, but additional strength tests must be conducted to account for the higher temperatures experienced by these materials while exposed to the standard fire.					
17. Key Words Engine mounts, Ultimate tensile strength loss, Fire			18. Distribution Statement This document is available to the public through the National Technical Information Service (NTIS), Springfield, Virginia 22161.		
19. Security Classif. (of this report) Unclassified		20. Security Classif. (of this page) Unclassified		21. No. of Pages 38	22. Price

TABLE OF CONTENTS

	Page
EXECUTIVE SUMMARY	vii
1. INTRODUCTION	1
2. TEST SPECIMENS, EQUIPMENT, AND INSTRUMENTATION	1
2.1 Specimens	1
2.2 Equipment	2
2.2.1 Modified Oil Burner	2
2.2.2 Specimen Fixture	2
2.3 Instrumentation	2
2.3.1 Data Acquisition System	3
2.3.2 Thermocouples	3
2.3.3 Calorimeter	3
2.3.4 Dial Indicator and Index-Rotational Device	3
3. PROCEDURES	3
3.1 Calibration	3
3.1.1 Temperature Calibration	4
3.1.2 Heat Flux Calibration	4
3.2 Burner Test	4
4. RESULTS	4
4.1 4130 Steel	5
4.2 15-5 PH Steel	5
4.3 Titanium 6A1-4V	5
4.4 Aluminum 7075	5
4.5 Inconel 718	6
5. REFERENCES	6

LIST OF FIGURES

Figure		Page
1	Oil Burner	7
2	Drawing of the Specimen Fixture	7
3	Specimen Fixture	8
4	Data Acquisition System	8
5	Bar Thermocouples Insulation	9
6	Thermocouple and Calorimeter Setup	10
7	Relative Position Between Calorimeters, Calibration Thermocouples, and Fire-Testing Zone	11
8	Calibration Calorimeters	11
9	Fire Test of 4130 Steel Bar	12
10	15-5 PH Steel Bar After Test	12
11	Aluminum 7075 Bar After Test	13
12	Time-Temperature Data During Test 1 of 4130 Steel	13
13	Time-Temperature Data During Test 2 of 4130 Steel	14
14	Time-Temperature Data During Test 3 of 4130 Steel	14
15	Time-Temperature Data During Test 4 of 4130 Steel	15
16	Time-Temperature Data During Test 5 of 4130 Steel	15
17	Time-Temperature Data During Test 1 of 15-5 PH Steel	16
18	Time-Temperature Data During Test 2 of 15-5 PH Steel	16
19	Time-Temperature Data During Test 3 of 15-5 PH Steel	17
20	Time-Temperature Data During Test 4 of 15-5 PH Steel	17
21	Time-Temperature Data During Test 5 of 15-5 PH Steel	18
22	Time-Temperature Data During Test 1 of Titanium 6Al-4V	18

23	Time-Temperature Data During Test 2 of Titanium 6A1-4V	19
24	Time-Temperature Data During Test 3 of Titanium 6A1-4V	19
25	Time-Temperature Data During Test 4 of Titanium 6A1-4V	20
26	Time-Temperature Data During Test 5 of Titanium 6A1-4V	20
27	Time-Temperature Data During Test 1 of Aluminum 7075	21
28	Time-Temperature Data During Test 2 of Aluminum 7075	21
29	Time-Temperature Data During Test 3 of Aluminum 7075	22
30	Time-Temperature Data During Test 4 of Aluminum 7075	22
31	Time-Temperature Data During Test 5 of Aluminum 7075	23
32	Time-Temperature Data During Test 1 of Inconel 718	23
33	Time-Temperature Data During Test 2 of Inconel 718	24
34	Time-Temperature Data During Test 3 of Inconel 718	24
35	Time-Temperature Data During Test 4 of Inconel 718	25
36	Test Fixture During the Determination of the Specimen Maximum Deflection	25
37	Test Fixture During the Determination of the Specimen Maximum Deflection Angular Location	26
38	Specimen Maximum Deflection Location	27

LIST OF TABLES

Table		Page
1	Test Specimen Description	28
2	Summary of Results	29
3	Comparison Between Test Data and MIL-Handbook-5H	30
4	Material Deformation Information	31

EXECUTIVE SUMMARY

The objective of the testing was to establish the tensile strength loss when candidate engine mount materials were exposed to a standard flame for 5 and 15 minutes. The exposure time dictates the fireproof rating of the material; i.e., a material will be fire resistant if it is capable of withstanding a 2000°F ($\pm 150^\circ\text{F}$) and 9.8 Btu/ft²·sec flame for 5 minutes and will be fireproof if it can withstand the same flame for 15 minutes while still fulfilling its design purpose. The test itself was a heat transfer test and not a strength test. Based on temperature measurements, a comparison was made of the loss of ultimate tensile strength (UTS) of a standardized specimen to a reference 4130 steel bar when both are engulfed isothermally to the standard flame. The UTS data of the materials was obtained from the MIL-Handbook-5H. The comparison metal bars tested were comprised of the following materials: 15-5 PH steel, titanium 6A1-4V, Inconel 718, and aluminum 7075.

The standardized specimens were mounted on a fixture 4 inches in front of the oil burner cone and 1 inch above the nozzle horizontal centerline. The 30-inch-long specimens were instrumented with five thermocouples to measure the temperature within the cross-sectional area (front, 25% of diameter, 50% of diameter, 75% of diameter, and back). Before the specimens were exposed to the flame, the flame itself was calibrated using seven thermocouples and four calorimeters; the temperature in all the thermocouples was ensured to be within 1850° and 2150°F and the heat flux on all the calorimeters was set to be above 9.8 Btu/ft²·sec. The specimen's attachment surface was insulated to minimize heat transfer to the surrounding metal surfaces. The flame was calibrated for 2 minutes and the test was conducted for a period of 16 minutes.

After the test was completed, the MIL-Handbook-5H was employed to determine the effects of the measured temperature on the tensile ultimate strength and the tensile yield strength of the different metal bars. It was observed that the data in the MIL-Handbook-5H did not account for the higher experimental temperatures. However, it was possible to conclude that the 4130 steel, which was the reference material, may have lost about 55% of its ultimate strength in the first 5 minutes, but its strength loss at 15 minutes could not be determined because the measured temperature exceeded the handbook's published temperature. Comparisons could not be done with the 15-5 PH steel and titanium 6A1-4V bars either because of the same reason. The titanium bar crept more than the other bars, with the exception of the aluminum bar, creeping 0.790" (maximum recorded) from its original shape. The steel and the Inconel bars did not have any significant creeping. Posttest observations revealed that the aluminum 7075 lost all of its strength since it melted and split in two pieces after 5 minutes exposure to the standardized fire. The Inconel 718 bar could only be compared with the handbook during the 5-minute reading. At that time, the bar reached 1412.1°F, and according to the handbook chart, the UTS percent loss was 50%. No comparison could be made with the 15-minute reading because of the reason explained above with regards to the handbook temperature data. During the test, the temperature (1644.6°F) exceeded the maximum temperature value (1480°F) plotted in the chart.

1. INTRODUCTION.

Code of Federal Regulations (CFR) Part 25.865 states “essential flight controls, engine mounts, and other flight structures located in designated fire zones or in adjacent areas which would be projected to the effects of fire in the fire zone must be constructed of fireproof material or shielded so that they are capable of withstanding the effects of fire.” Steel has traditionally been accepted as a standard for fireproof material structures. For other materials intended to carry loads and resist failure under intense heat, equivalency to steel must be substantiated. Although CFR Part 1.1 provides general definitions for the expressions fireproof and fire resistant, they do not specify certain parameters associated with testing to positively classify materials into these groupings. For the purpose of these tests, the definition of fireproof and fire resistant, as defined on Advisory Circular 20-135 [1], was used to examine the tested materials.

- a. Fireproof: The capability of a material to withstand, as well as or better than steel, a 2000°F flame ($\pm 150^\circ\text{F}$) for 15 minutes minimum while still fulfilling its design purpose. The term fireproof, when applied to materials and parts used to confine fires within designated fire zones, means that the material or part will perform this function under conditions likely to occur in such zones and will withstand a 2000°F flame (150°F) for 15 minutes minimum.
- b. Fire Resistant: When applied to power plant installations such as fluid-carrying lines, flammable fluid system components, wiring, air ducts, fittings, and power plant controls, fire resistant means the capability of a material or component to perform its intended functions under the heat and other conditions likely to occur at the particular location and to withstand a 2000°F flame ($\pm 150^\circ\text{F}$) for 5 minutes minimum.

The primary objective of the testing was to measure the temperature within different solid metal cylinders subjected to a standard flame and attempt to determine the impact of the elevated temperature on the strength of the metals.

2. TEST SPECIMENS, EQUIPMENT, AND INSTRUMENTATION.

The fire tests were conducted in test cell 1 of building 287 of the Federal Aviation Administration (FAA) William J. Hughes Technical Center. The test equipment and instrumentation used included a modified oil burner (figure 1), specimen fixture (figure 2), data acquisition system, thermocouples, and calorimeters; as described in the following subsections.

2.1 SPECIMENS.

The specimen materials tested in this program were 4130 steel (reference), 15-5 PH steel, titanium 6Al-4V, aluminum 7075, and Inconel 718. The physical dimensions and weight of each specimen are tabulated in table 1. The specimens were solid metal bars cut to 30" ($\pm 1/16$) in length. Their diameter varied because the specimens were machined to sustain the same ultimate tensile load as the reference material (4130 steel), i.e., 88,355 lbf. On this basis, the diameters of the comparison bars were determined using the following equation:

$$\phi_{com} = \phi_{ref} \times \sqrt{\frac{Ftu_{ref}}{Ftu_{com}}} \quad (1)$$

where:

ϕ_{com} = Diameter of comparison bar

ϕ_{ref} = Diameter of reference bar

Ftu_{com} = Ultimate tensile stress of comparison bar

Ftu_{ref} = Ultimate tensile stress of reference bar

Three small orifices, 5/64" in diameter, were drilled in each specimen for placement of the thermocouples used to sense its internal temperature. The depth of the hole depended on the percentage of the cross-sectional area being monitored (25%, 50%, and 75% of the diameter).

2.2 EQUIPMENT.

2.2.1 Modified Oil Burner.

The oil burner was a modified gun type, Park Model DPL 3400 oil burner (figure 1). A Monarch nozzle was installed in the burner to maintain a fuel flow of 2.1 gal/hr, an 80° AR spray pattern, an average airflow of 1800 fpm, and a fuel pressure of 94 lb/in². Jet A fuel was used as the fuel. An Internal Turbulator H215 and End Turbulator F124 were installed inside the draft tube and at the end of the draft tube. A 12- ±1/8-inch burner cone was installed at the end of the draft tube. The cone was made of stainless steel and had a thickness of 0.065 ±0.015 inch. The opening of the cone was 6 ±1/4 inches high and 11 ±1/4 inches wide. A vane-type air-sensing anemometer was used to monitor the flow of the air at the inlet of the oil burner. The inlet was completely sealed except for an opening for the air velocity sensor. Flame characteristics were enhanced by the optional use of metal tabs installed on the end turbulator.

2.2.2 Specimen Fixture.

The specimens were mounted, in the main specimen fixture frame shown in figures 2 and 3. This fixture was made of 0.125-inch thick welded angled iron, square tubes, and rods. A removable secondary structure, which was a frame made of 0.125" thick and 1.75" wide angled iron, contained the test specimen and a Kaowool backboard. This frame was clamped to the top of the calorimeter frame during the burn test. This frame had two V-notches on the middle of its left and right side members, used to place the specimens and align them according to the test protocols. The main specimen fixture frame also housed the calibration thermocouples and calorimeters. The main frame measured 46 inches wide by 64 inches high by 3/4 inch deep. The frame holding the Kaowool in place measured 28.25 inches wide by 12 inches high by 1.75 inches deep.

2.3 INSTRUMENTATION.

The instrumentation used to collect the test data included a data acquisition system, thermocouples, and calorimeters. For posttest measurements, a dial indicator and an index-rotational device were used to measure the deformity (creep) and location on the material.

2.3.1 Data Acquisition System.

The data collection system was comprised of a Computer Boards Inc. PCM-DAS 16S/12 and a CIO-EXP16 system connected to a Gateway Solo (Pentium II) laptop computer (figure 4). Each data channel was programmed in HP VEE to record once every second.

2.3.2 Thermocouples.

The specimen bars were instrumented with thermocouples to determine their internal temperature gradient. The five thermocouples attached to the specimen bars were placed in front of the bar (1/4" away from the bar's surface), embedded inside the bar at 25%, 50%, and 75% of its diameter, and on its backside (figure 5). Also, there was a thermocouple pile, with seven thermocouples, that was used during the calibration of the flame. The sensing beads of these calibration thermocouples were located 4 inches in front of the vertical plane of the oil burner's cone exit and 1 inch above the horizontal centerline of the burner cone [2]. Temperature measurements were taken with thermocouples model JSM 1K1EJG24ZZZZZBZ; this thermocouple model was Type K, had grounded junction, the wires were 24 AWG, and it had a 1/16" diameter sheath.

2.3.3 Calorimeter.

Four calorimeters, Vatell model 1000-1A (FAA gage), were used during the calibration of the oil burner to determine the total heat flux of the fire. These calorimeters were also located 4 inches from the vertical plane and offset 1 inch above the horizontal centerline of the burner cone exit (figures 6, 7, and 8). The calorimeters' mounting fixture was interchangeable with the test specimen frame.

2.3.4 Dial Indicator and Index-Rotational Device.

In order to measure any distortion, such as creeping, on the material due to the heat, a dial indicator and an index-rotational device were used. A K-D Tools 0- to 1-inch dial indicator, 1/1000 graduated, was used to measure the deflection on the bars. An L-W index-rotational device, from Chuck Company, was used to find the maximum deflection angular location. The accuracy of the index-rotational device was 9 degrees per revolution and capable of reading at an increment of 0.273 degree.

3. PROCEDURES.

The oil burner was calibrated, on a daily basis, prior to conducting the burn test. After calibration, the calorimeter-holding fixture was removed from the test fixture, the thermocouple pile was lowered, and the specimen frame was mounted in the calibrated fire zone. After mounting the test specimen, the following oil burner procedures test were employed. The following sections describe each procedure in detail.

3.1 CALIBRATION.

Two types of calibration were conducted on the oil burner prior to beginning the tests: temperature calibration and total heat flux calibration. The instrumentation setup is shown in figure 6.

3.1.1 Temperature Calibration.

The seven calibration thermocouples were installed, as a thermo pile, in the fire zone to check the oil burner's flame temperature. Each thermocouple was spaced $1 \pm 1/16$ inch apart from each other, $4 \pm 1/8$ inches from the vertical plane, and offset $1 \pm 1/16$ inch above the horizontal centerline of the burner cone exit (figures 5, 6, and 7). The burner was turned away (rotated 90° away from the fire zone) from the thermocouples and allowed to preheat for 2 minutes. The burner was then directed towards the thermocouples for 90 seconds. During this period, the transient temperature was recorded with analog-to-digital converters and displayed in real time. The oil burner was adjusted to produce a flame temperature between 1850° and 2150°F , as measured by each thermocouple.

3.1.2 Heat Flux Calibration.

The oil burner was also calibrated, to produce a total heat flux at or above $9.8 \text{ Btu/ft}^2\text{-sec}$. This was accomplished by using the four calorimeters described previously. The distance of each of the four calorimeters was $4 \pm 1/8$ inches from the vertical plane and offset $1 \pm 1/16$ inch above the horizontal centerline of the burner cone exit. The burner was rotated away from the calorimeters (fire zone) and allowed to preheat for 2 minutes. The burner was then directed towards the calorimeters for 90 seconds. The heat flux was recorded with analog-to-digital converters.

3.2 BURNER TEST.

After calibrating the oil burner, the specimen-mounting frame was attached to the test fixture in a manner that exposed the test samples to the same calibration fire intensity. Prior to installing the specimen-mounting frame on the test fixture, the specimen bar was instrumented with five thermocouples and securely fastened to the frame. The thermocouples were installed to measure the external (0%) and imbedded internal temperatures of the test specimen at 25%, 50%, 75%, and 100% (backside) of the diameter (see figure 5). The thermocouple placed at the 0% mark was aligned on the outside of the bar and in direct contact with the flame. The thermocouple was insulated with fiberglass tape except for the last $1/2$ inch, which was raised about a $1/4$ inch from the bar and into the flame. This was performed to ensure the flame produced the correct temperature and to minimize conduction from the bar. The test specimen was placed $4 \pm 1/8$ inches from the vertical plane and offset $1 \pm 1/16$ inch above the horizontal centerline of the burner cone exit. Each rod was insulated at the ends to reduce heat transfer from external materials and to produce a bar in space scenario. The burner was rotated away from the test specimen and allowed to preheat for 2 minutes. The burner was then immediately directed towards the test sample, which was heated for 16 minutes (see figure 9). The transient specimen bar temperatures were recorded with analog-to-digital converters.

4. RESULTS.

The results of the burn tests on all five specimens are detailed in the following sections. Table 2 provides a summary of the test results, figures 10 and 11 are posttest photographs, and figures 12 through 35 show the time-temperature plots. Figures 36-38 show the tools and technique used to measure the creeping effects of the tested materials. After calibrating the oil burner, each type of metal was tested five times. The average temperature of the thermocouple located at the 50% position was used for the comparative analysis (table 3). To be considered fire resistant, the residual strength of the test specimen at the 5-minute mark must be equal to or greater than the

residual strength of the 4130 steel (reference material) at this time. To be considered fireproof, the residual strength of the test specimen at the 15-minute mark must be equal to or greater than the residual strength of 4130 steel (reference material) at that time. However, since the measured temperatures were generally greater than what was available on the temperature-strength graphs in the MIL-Handbook-5H [3], it was difficult to characterize the specimens. Table 4 provides the material deformation information.

4.1 4130 STEEL.

After 5 minutes into the burner test, the average temperature of the thermocouple located at the 50% location was 1131.53°F, corresponding to a residual strength of approximately 45%, as viewed in the MIL-Handbook-5H. After 15 minutes, the average temperature of the same thermocouple was 1513.70°F. Unfortunately, the highest temperature in the MIL-Handbook-5H is 1200°F, where the residual strength is 36%. The deflection of each bar was measured after the burn test, and the average deflection was 0.172" at 127.80° (clockwise) from the thermocouple holes.

4.2 15-5 PH STEEL.

After 5 minutes, the average temperature of the thermocouple located at the 50% location reached was 1117.4°F. After 15 minutes, the average temperature of the same thermocouple was 1611.85°F. The highest temperature-strength data in the MIL-Handbook-5H for 15-5 PH steel was only 800°F, which corresponds to a residual strength of 79.5%; therefore, a determination could not be made of the residual strength at 5 and 15 minutes. The deflection of each bar was measured after the burn test, and the average deflection was 0.172" at 143.95° (clockwise) from the thermocouple holes. Coincidentally, this was the same average deflection as measured with the 4130 steel.

4.3 TITANIUM 6A1-4V.

After 5 minutes, the average temperature of the thermocouple located at the 50% location was 1496.48°F. After 15 minutes, the temperature of the same thermocouple was 1646.88°F. The temperature-strength data in the MIL-Handbook-5H for titanium 6A1-4V extended to only 1000°F, which corresponds to a residual strength of 51%. Therefore, a comparison between the two data sources could not be done. The deflection of each bar was measured after the burn test, and the average deflection was 0.552" at 231.71° (clockwise) from the thermocouple holes. Titanium experienced a significant amount of creeping when compared to the steels and Inconel. The deflection was towards the flame.

4.4 ALUMINUM 7075.

After 5 minutes, the temperature of the thermocouple located at the 50% location was 1115.6°F. Unfortunately, the highest temperature in the MIL-Handbook-5H for aluminum 7075 is 600°F, where the residual strength is only 11.5%. Shortly after the 5-minute test period, the creep of the aluminum 7075 became so drastic that it began melting away; therefore, the test was terminated.

4.5 INCONEL 718.

After 5 minutes, the temperature of the thermocouple located at the 50% location was 1412.09°F, corresponding to a residual strength of approximately 50%, as viewed in the MIL-Handbook-5H. This residual strength would classify Inconel as a fire-resistant material. After 15 minutes, the temperature of the same thermocouple was 1644.63°F. Unfortunately, the highest temperature in the MIL-Handbook-5H for Inconel 718 is 1500°F, where the residual strength is only 36%. The deflection was measured after the burn test, and the average deflection was 0.054" at 97.98° (clockwise) from the thermocouple holes. Inconel experienced the least amount of creeping deflection compared to the other materials.

5. REFERENCES.

1. FAA Advisory Circular 20-135, "Powerplant Installation and Propulsion System Component Fire Protection Test Methods, Standards, and Criteria," February 1990.
2. Aircraft Materials Fire Test Handbook, Chapter 7, Oil Burner Test For Seat Cushions, 7.7 Calibration.
3. MIL-Handbook-5H Compact Disk, December 1998.



FIGURE 1. OIL BURNER

Removable Framed Kaowool (Refractory Ceramic Fiber) Board to insulate thermocouples and provide a uniform and consistent fire impingement surface.

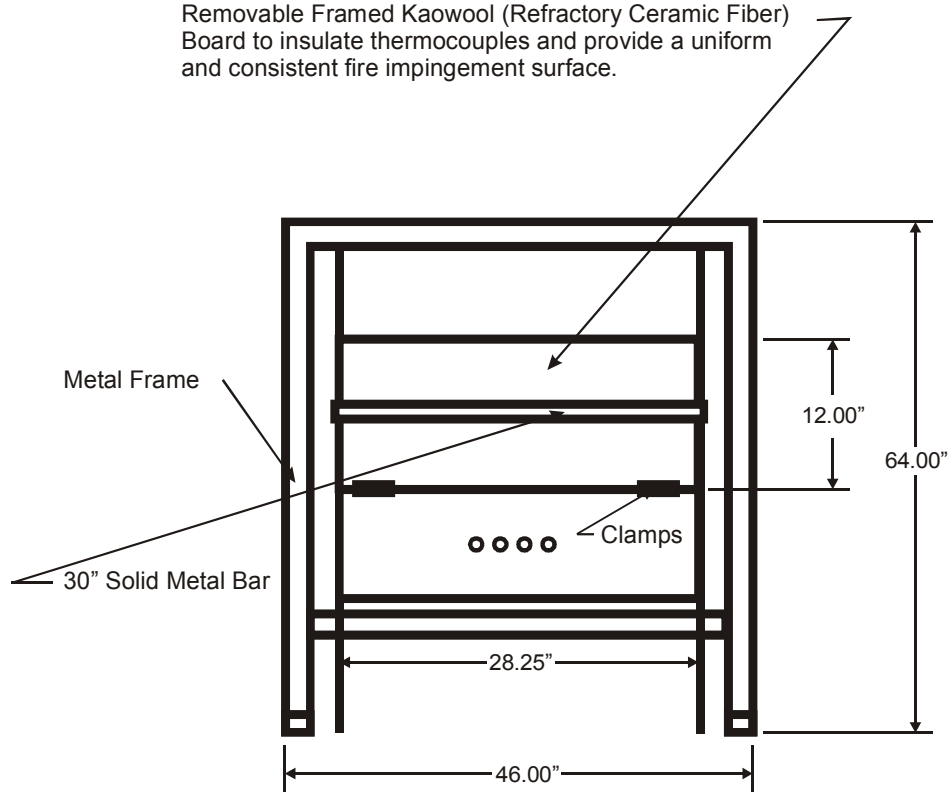

FIGURE 2. DRAWING OF THE SPECIMEN FIXTURE



FIGURE 3. SPECIMEN FIXTURE



FIGURE 4. DATA ACQUISITION SYSTEM

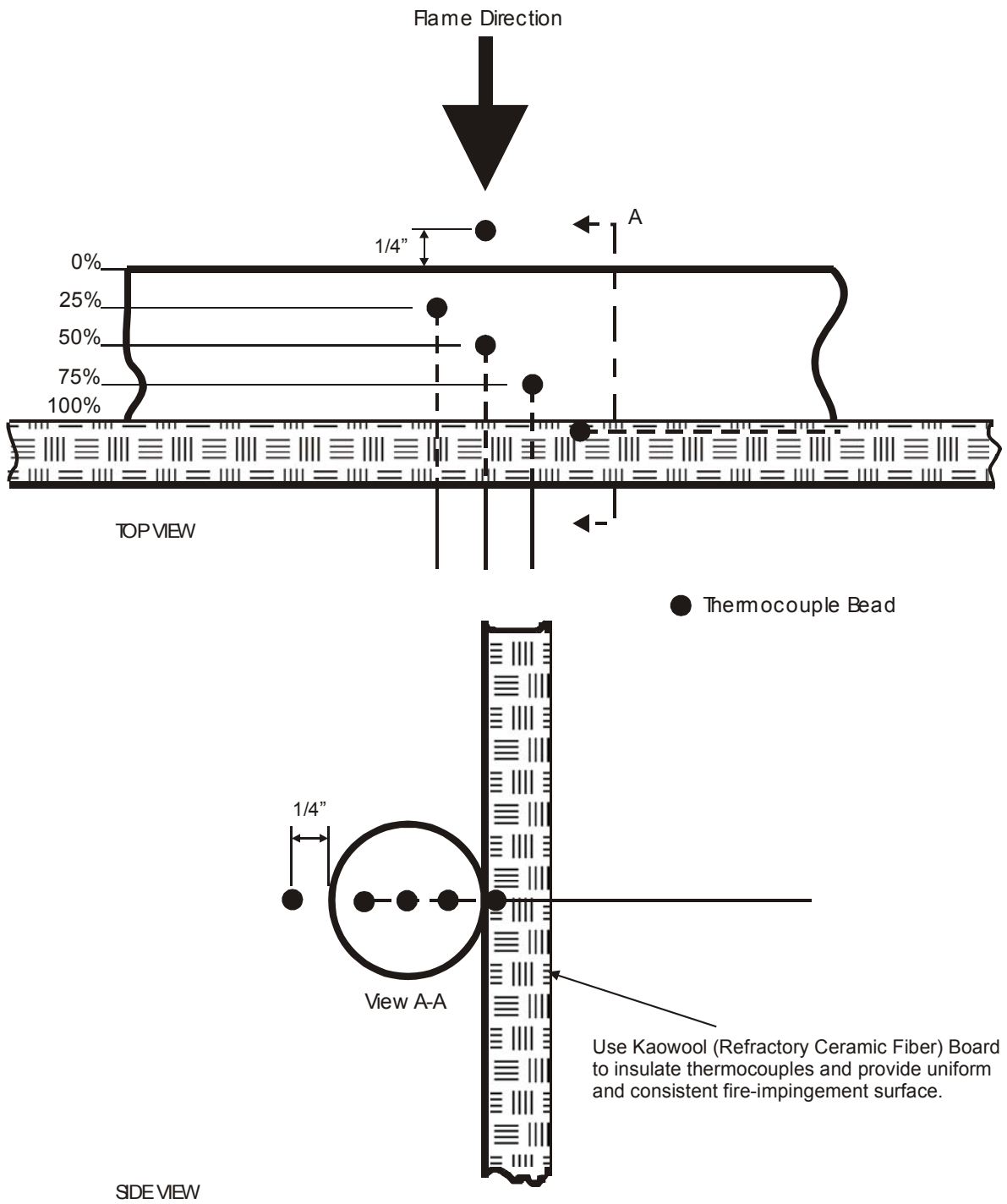
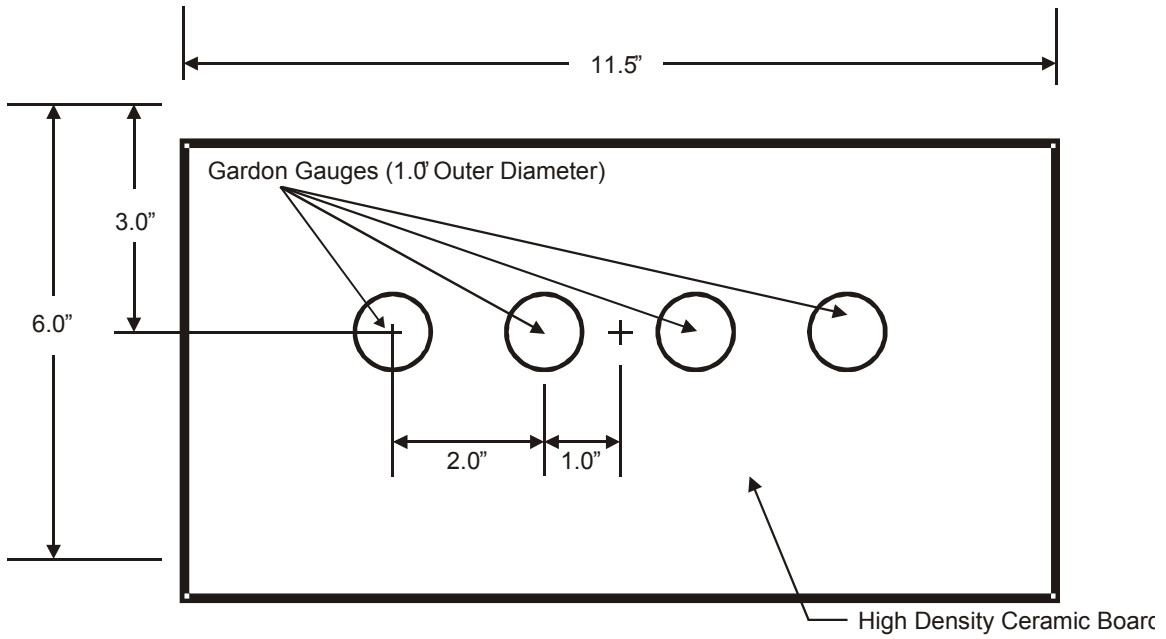
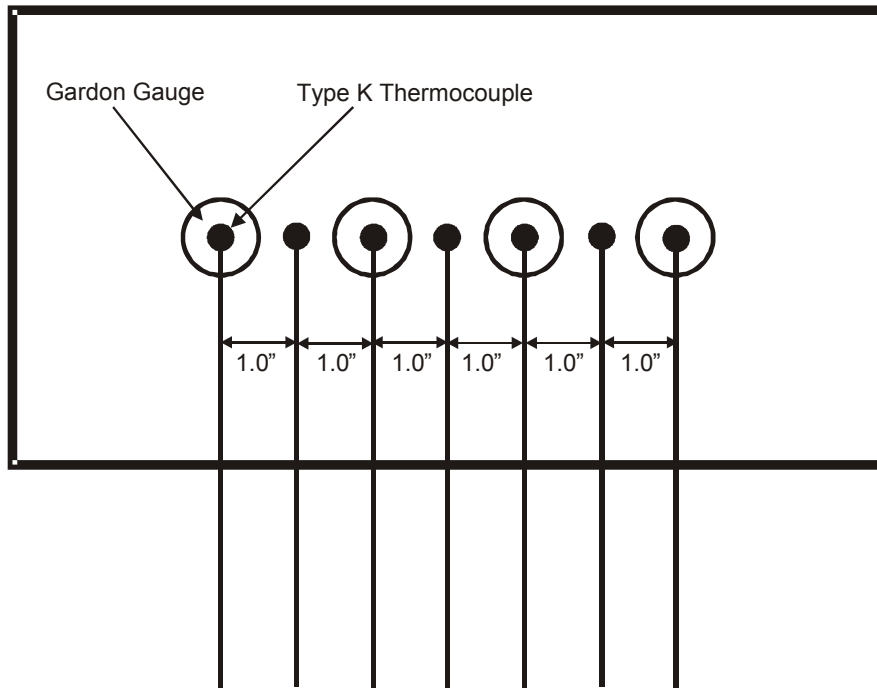

FIGURE 5. BAR THERMOCOUPLES INSULATION



(a) Calorimeters Setup. Calibrate the oil burner using four total heat flux (Gardon gauges) in addition to the seven thermocouples. This will map the heat flux in fire-testing zone.



(b) Relative position between calorimeters and thermocouples

FIGURE 6. THERMOCOUPLE AND CALORIMETER SETUP

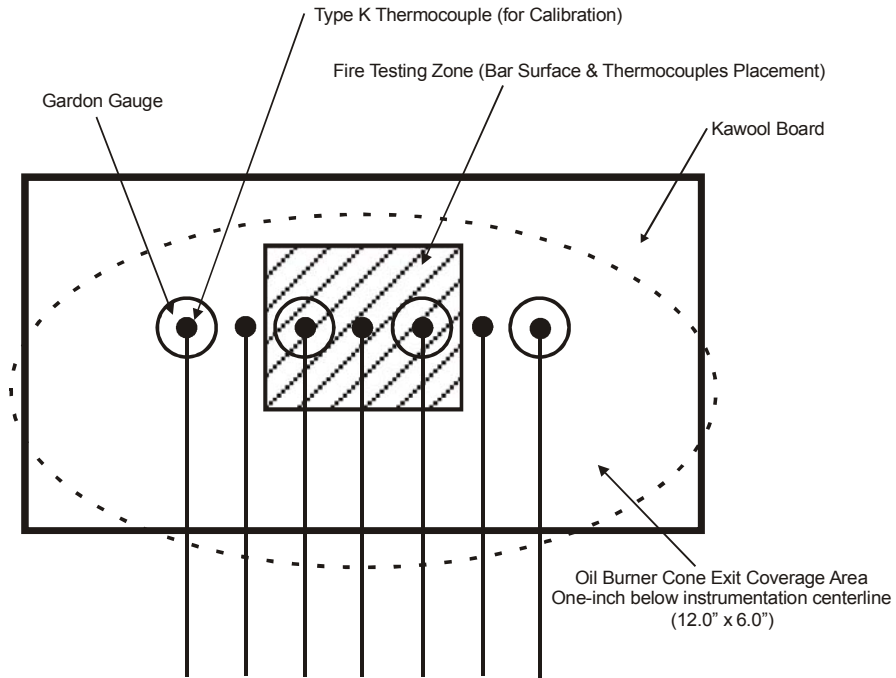

FIGURE 7. RELATIVE POSITION BETWEEN CALORIMETERS, CALIBRATION THERMOCOUPLES, AND FIRE-TESTING ZONE



FIGURE 8. CALIBRATION CALORIMETERS



FIGURE 9. FIRE TEST OF 4130 STEEL BAR



FIGURE 10. 15-5 PH STEEL BAR AFTER TEST



FIGURE 11. ALUMINUM 7075 BAR AFTER TEST

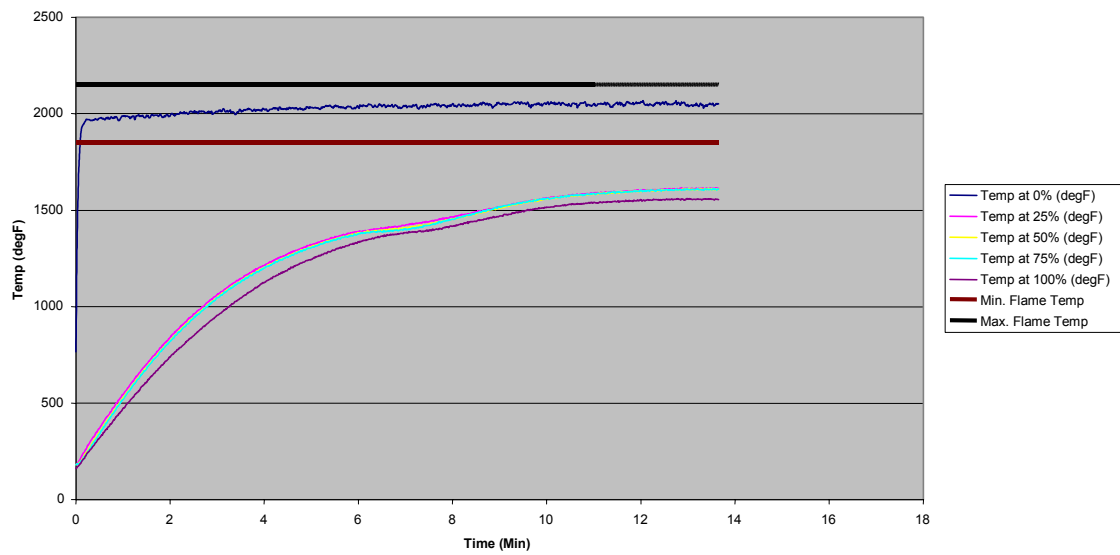

FIGURE 12. TIME-TEMPERATURE DATA DURING TEST 1 OF 4130 STEEL

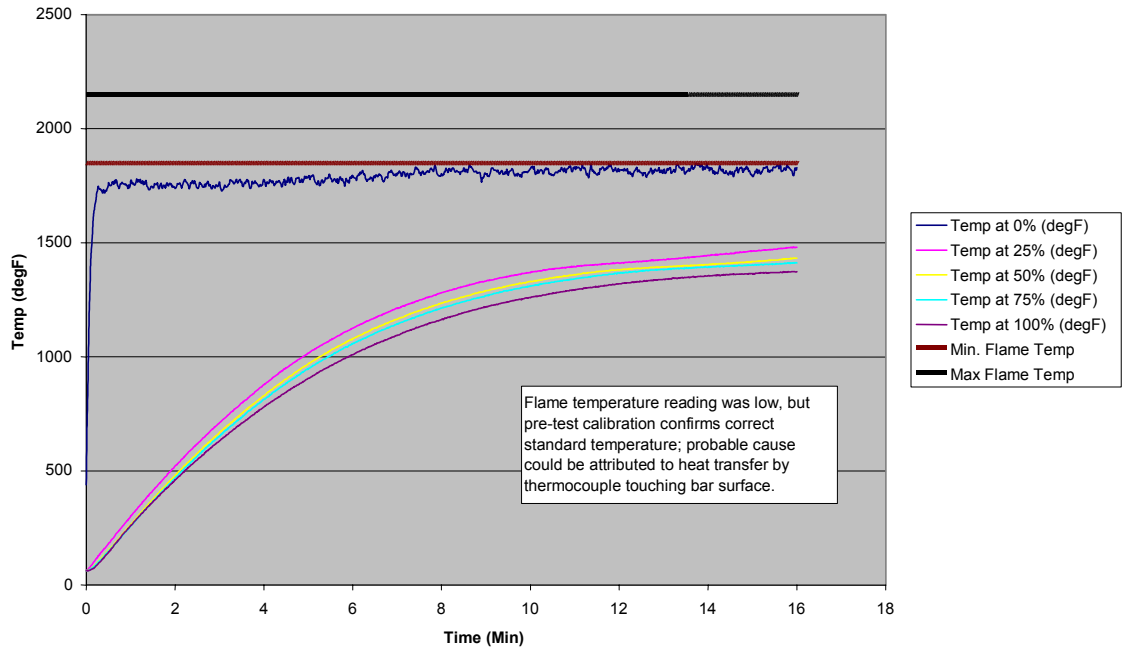

FIGURE 13. TIME-TEMPERATURE DATA DURING TEST 2 OF 4130 STEEL

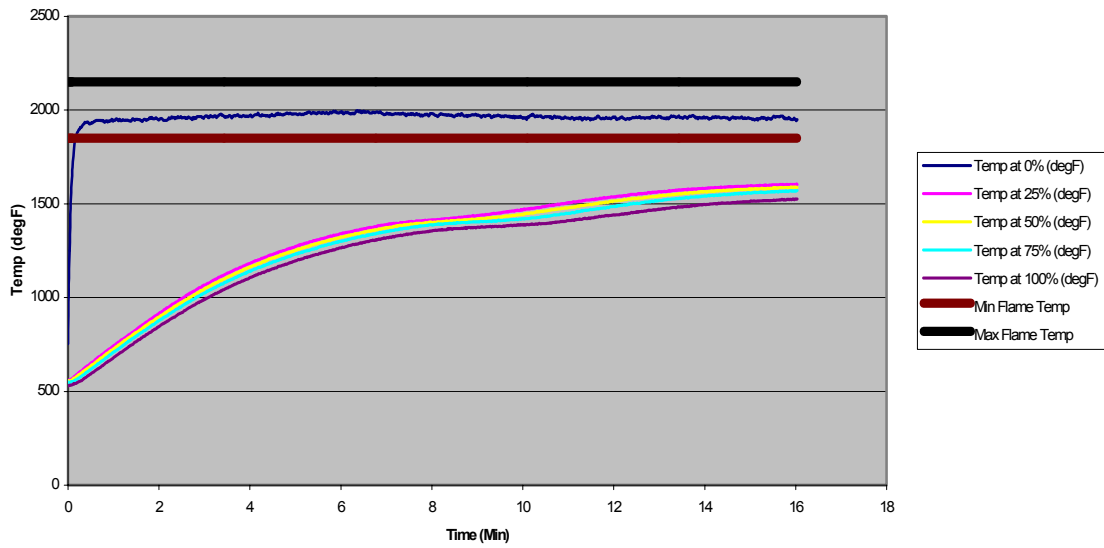

FIGURE 14. TIME-TEMPERATURE DATA DURING TEST 3 OF 4130 STEEL

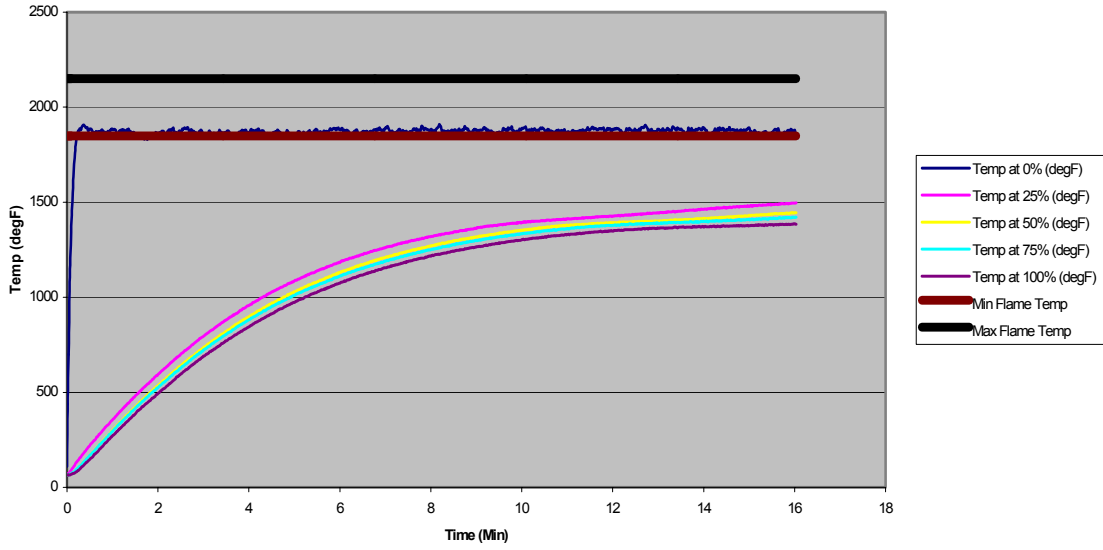

FIGURE 15. TIME-TEMPERATURE DATA DURING TEST 4 OF 4130 STEEL

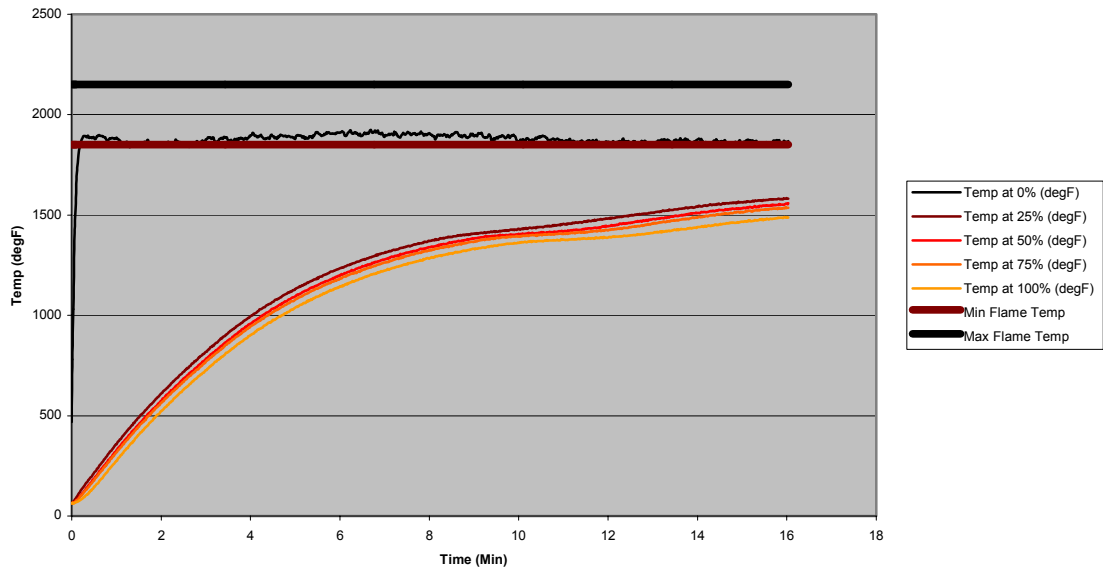

FIGURE 16. TIME-TEMPERATURE DATA DURING TEST 5 OF 4130 STEEL

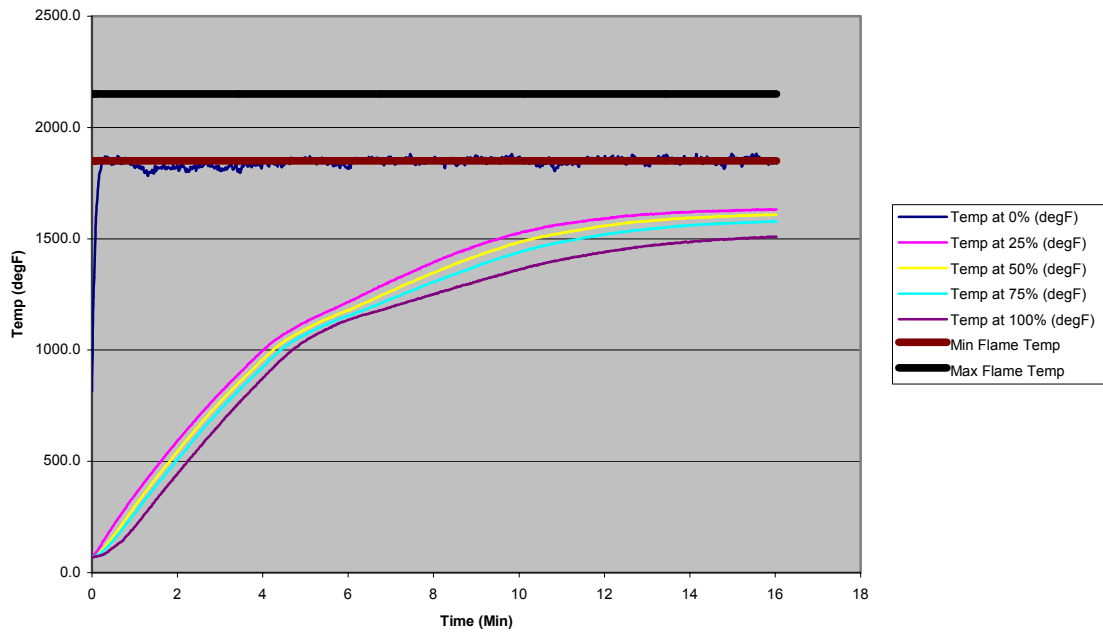

FIGURE 17. TIME-TEMPERATURE DATA DURING TEST 1 OF 15-5 PH STEEL

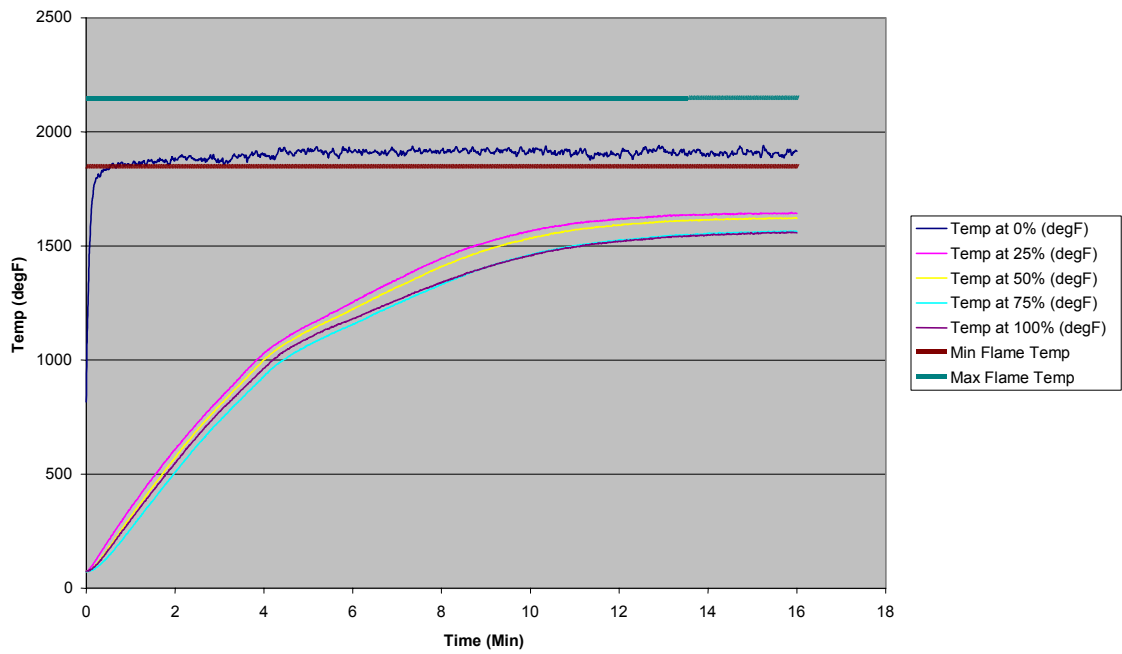

FIGURE 18. TIME-TEMPERATURE DATA DURING TEST 2 OF 15-5 PH STEEL

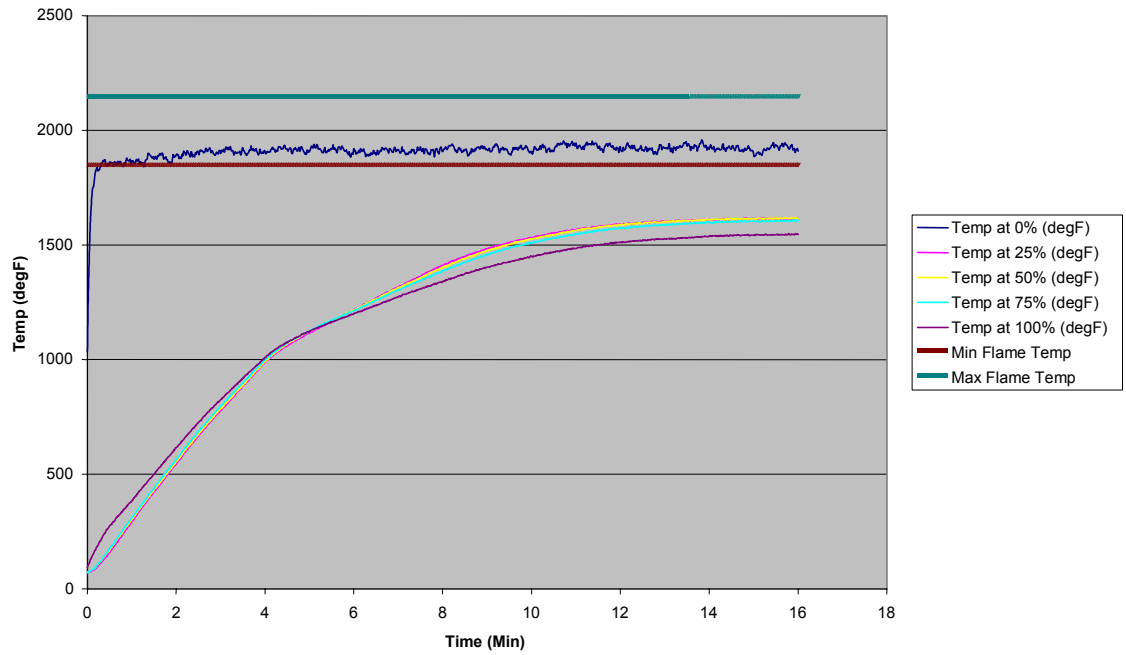

FIGURE 19. TIME-TEMPERATURE DATA DURING TEST 3 OF 15-5 PH STEEL

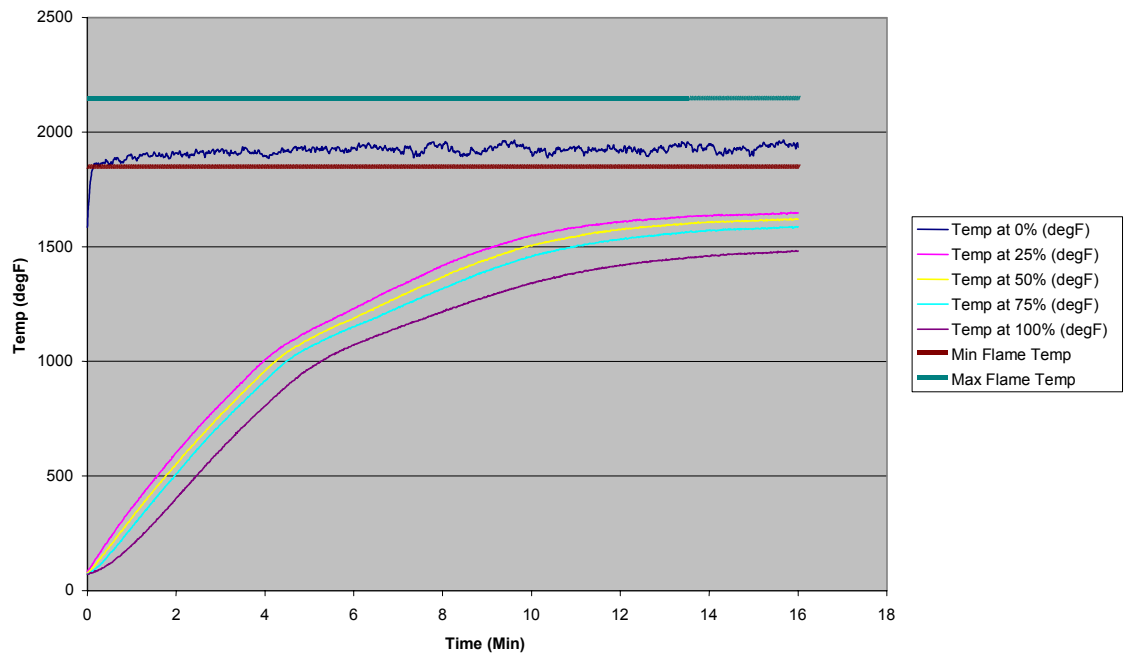

FIGURE 20. TIME-TEMPERATURE DATA DURING TEST 4 OF 15-5 PH STEEL

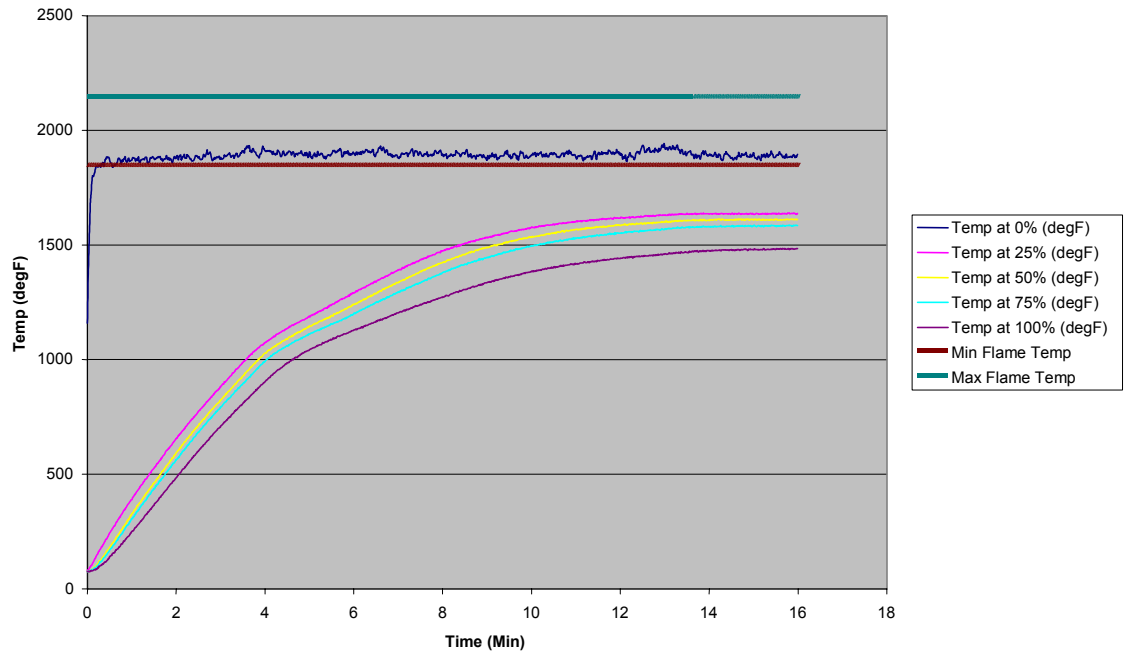

FIGURE 21. TIME-TEMPERATURE DATA DURING TEST 5 OF 15-5 PH STEEL

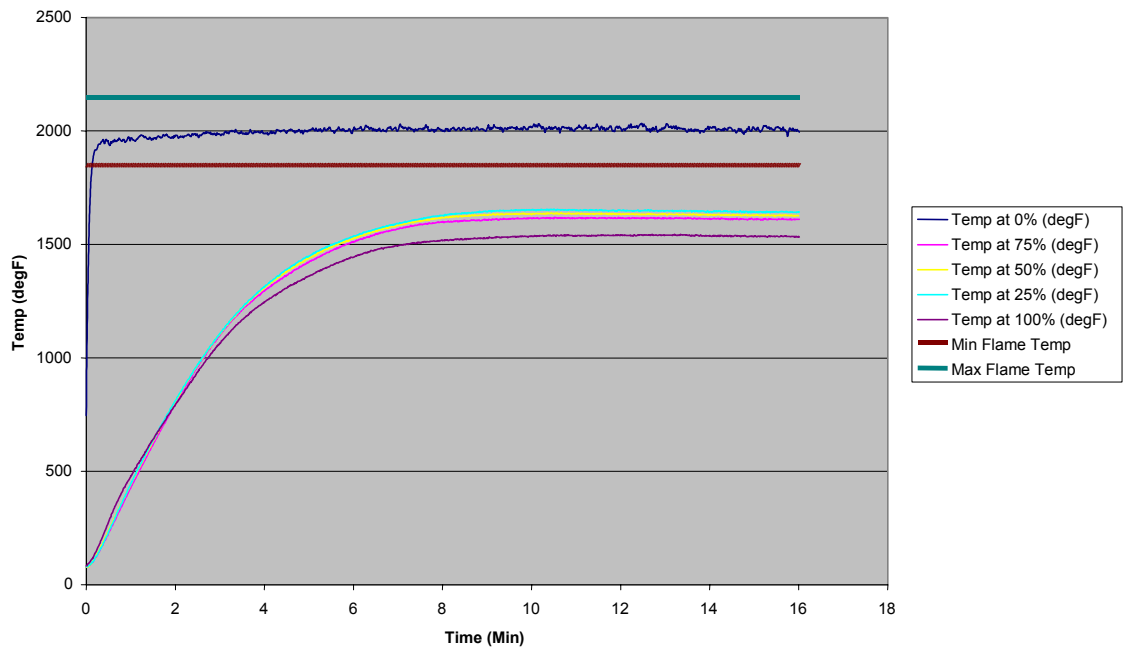

FIGURE 22. TIME-TEMPERATURE DATA DURING TEST 1 OF TITANIUM 6A1-4V

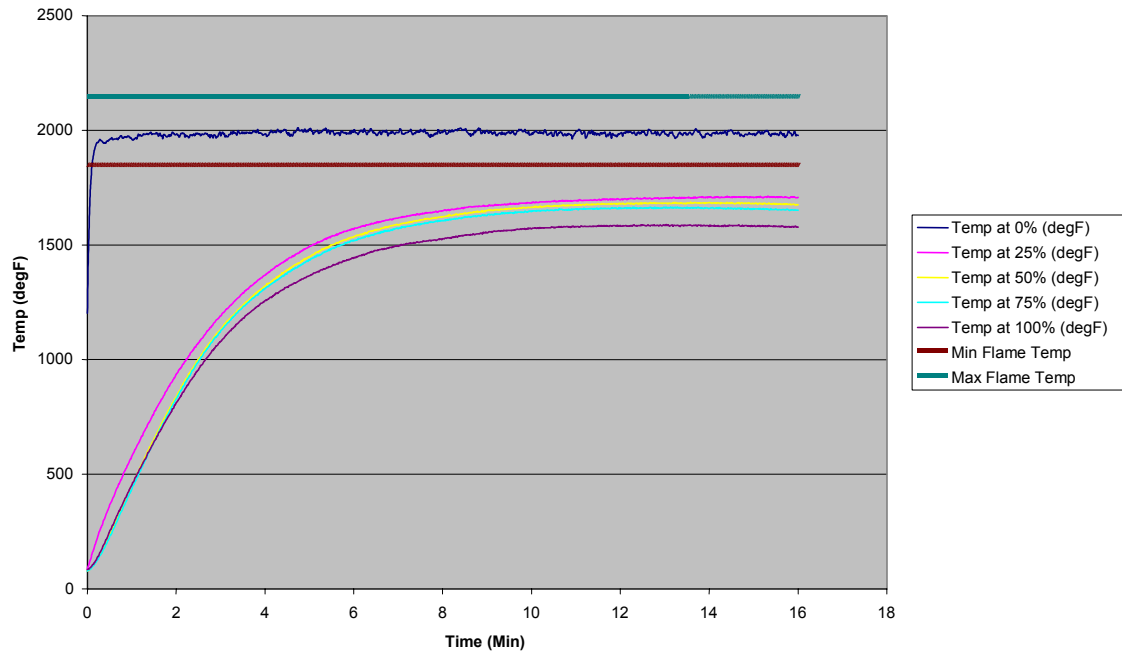

FIGURE 23. TIME-TEMPERATURE DATA DURING TEST 2 OF TITANIUM 6A1-4V

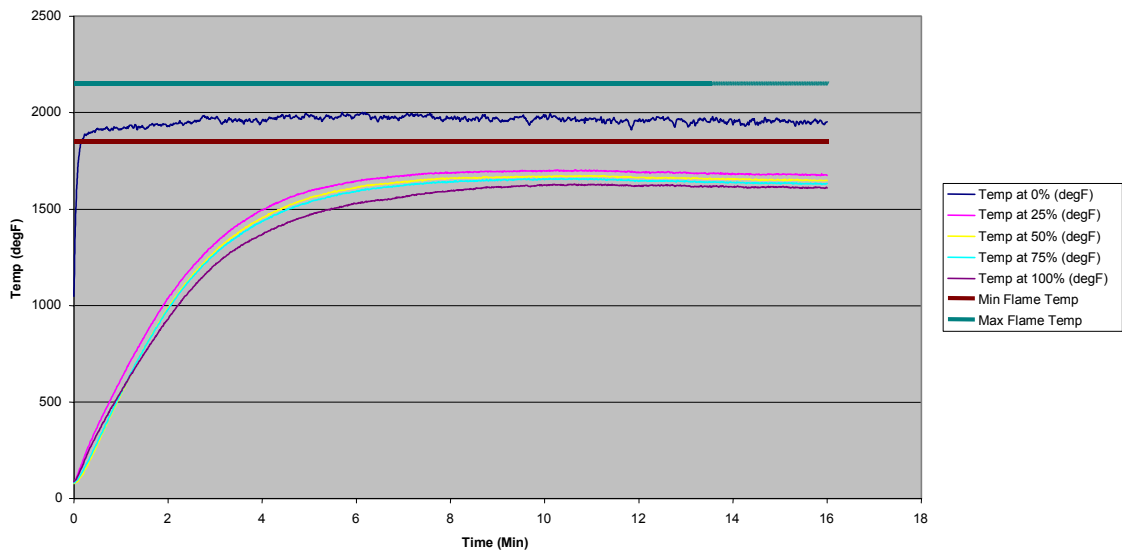

FIGURE 24. TIME-TEMPERATURE DATA DURING TEST 3 OF TITANIUM 6A1-4V

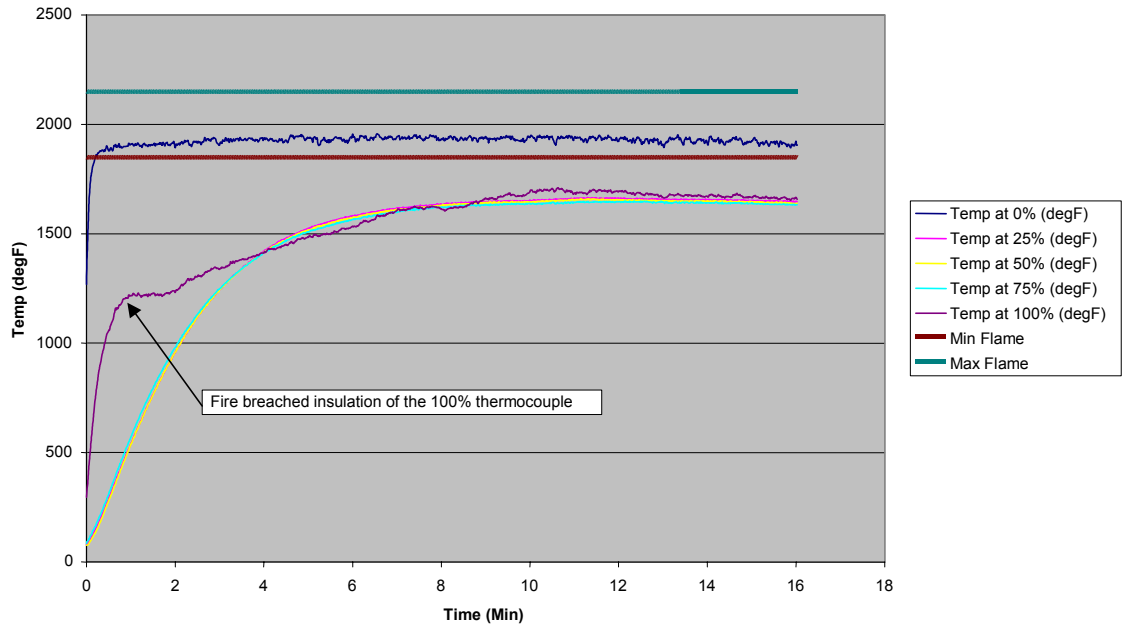

FIGURE 25. TIME-TEMPERATURE DATA DURING TEST 4 OF TITANIUM 6A1-4V

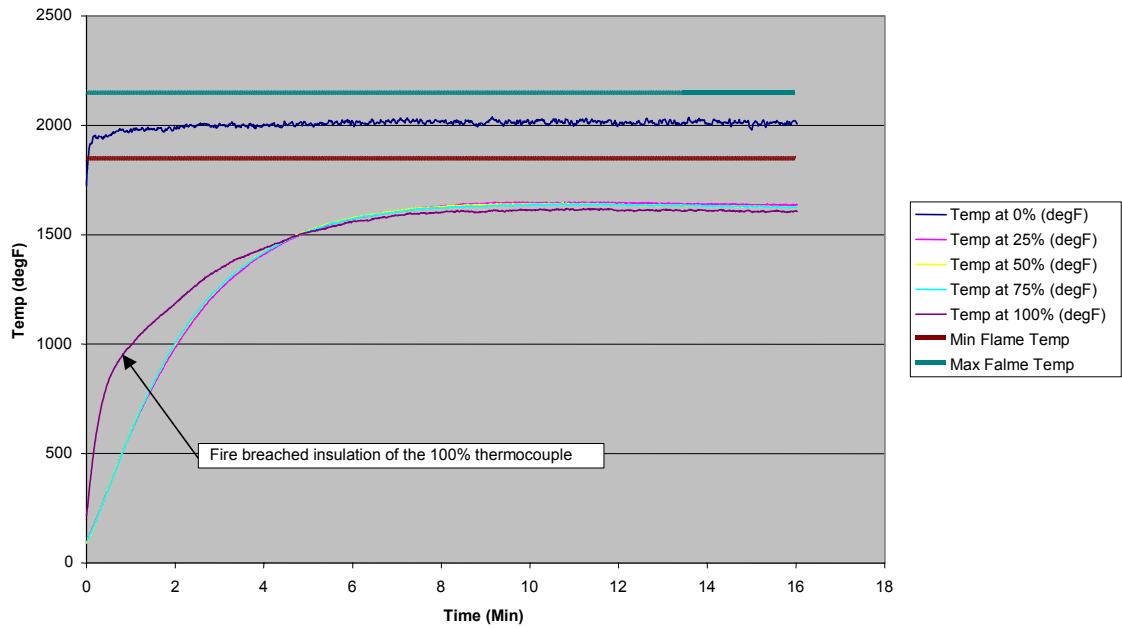

FIGURE 26. TIME-TEMPERATURE DATA DURING TEST 5 OF TITANIUM 6A1-4V

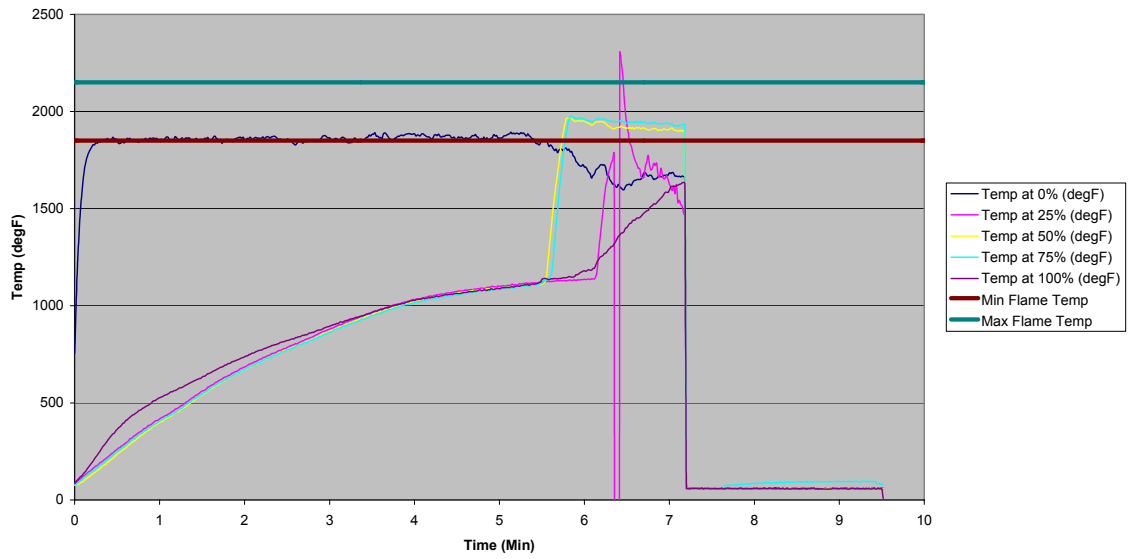

FIGURE 27. TIME-TEMPERATURE DATA DURING TEST 1 OF ALUMINUM 7075

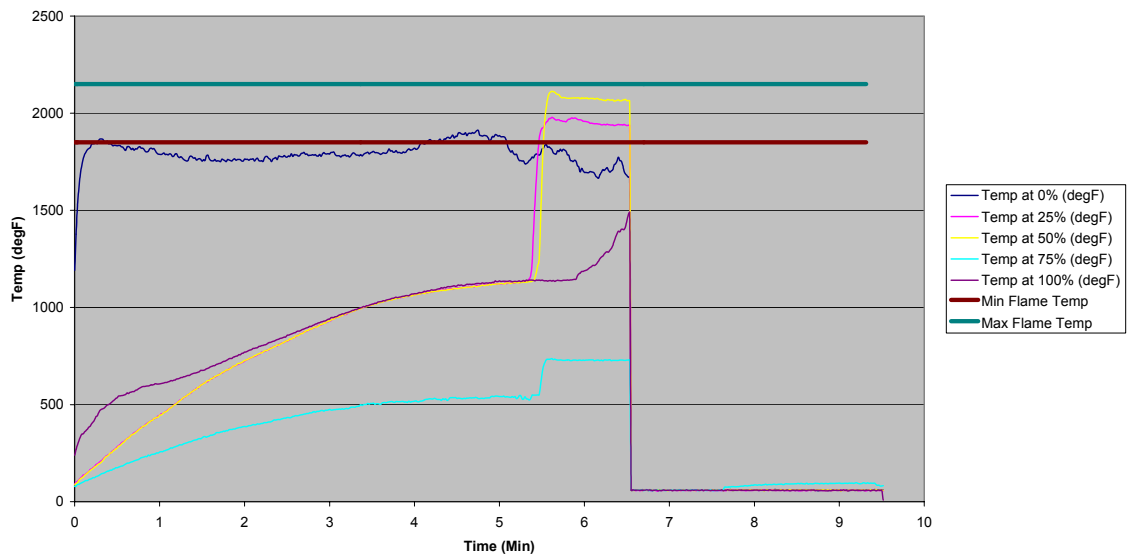

FIGURE 28. TIME-TEMPERATURE DATA DURING TEST 2 OF ALUMINUM 7075

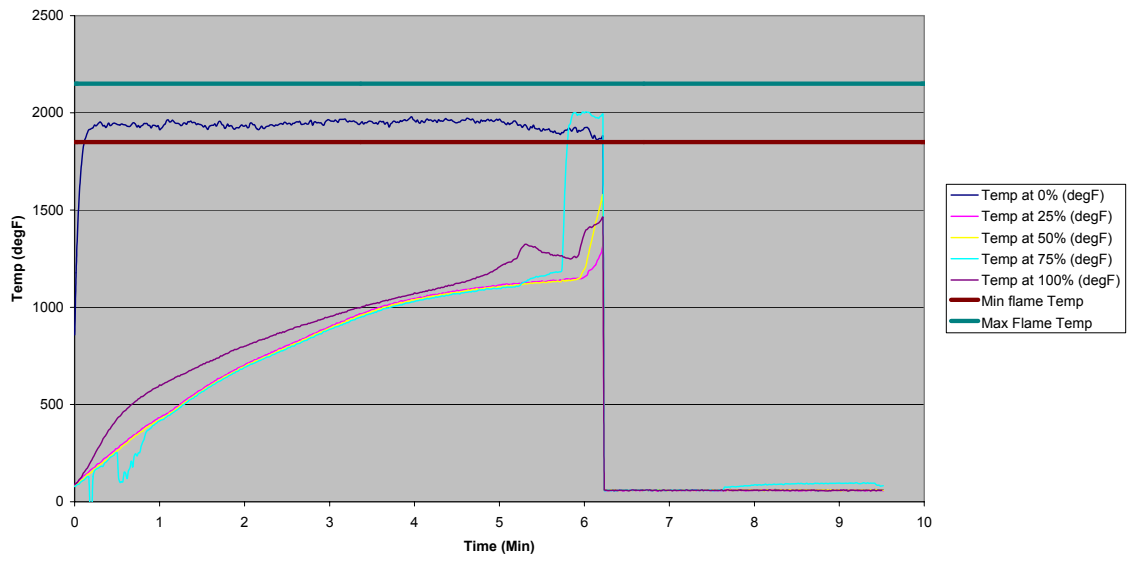

FIGURE 29. TIME-TEMPERATURE DATA DURING TEST 3 OF ALUMINUM 7075

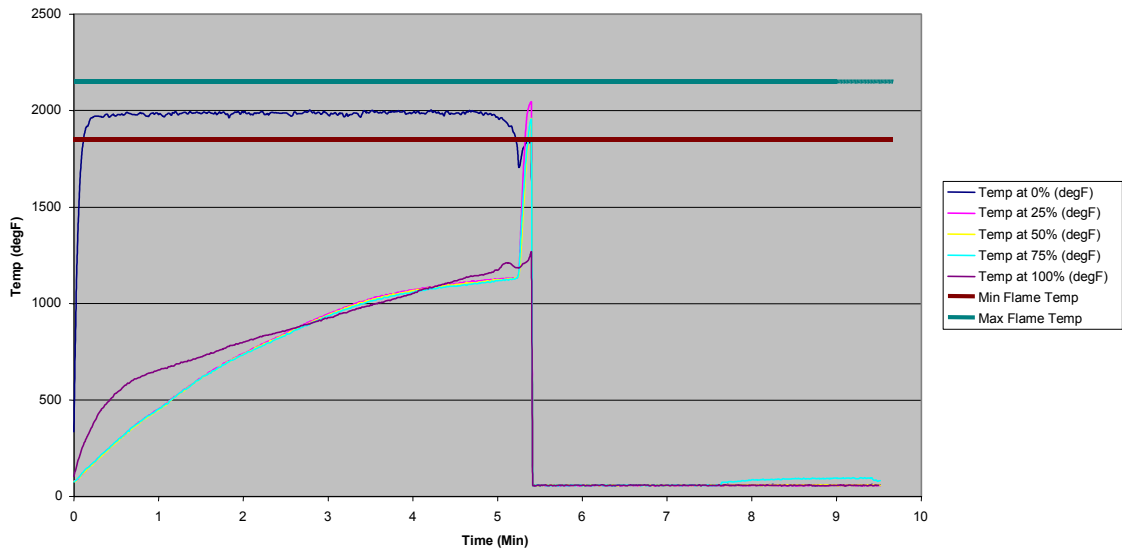

FIGURE 30. TIME-TEMPERATURE DATA DURING TEST 4 OF ALUMINUM 7075

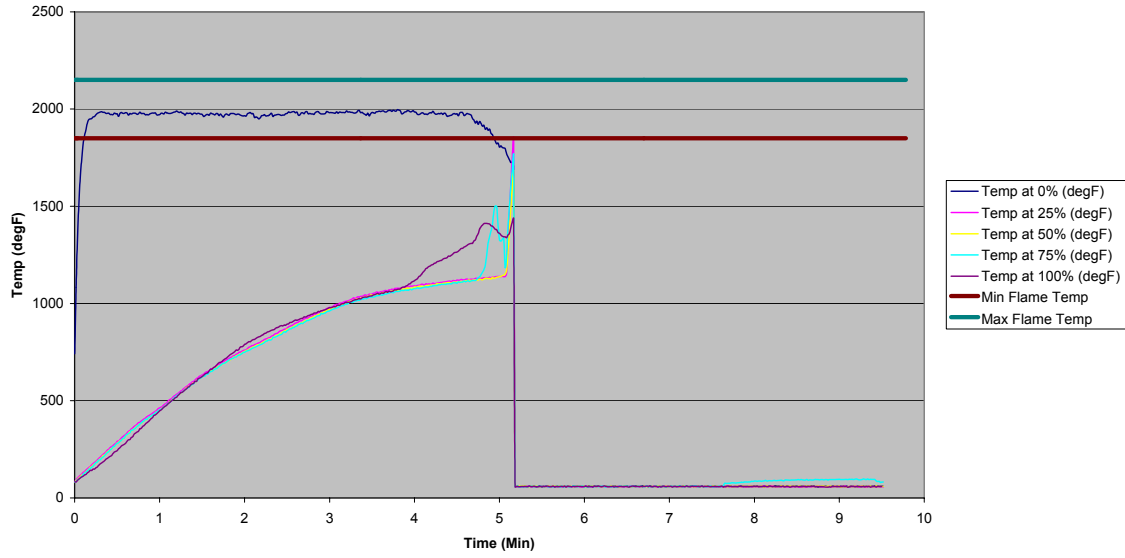

FIGURE 31. TIME-TEMPERATURE DATA DURING TEST 5 OF ALUMINUM 7075

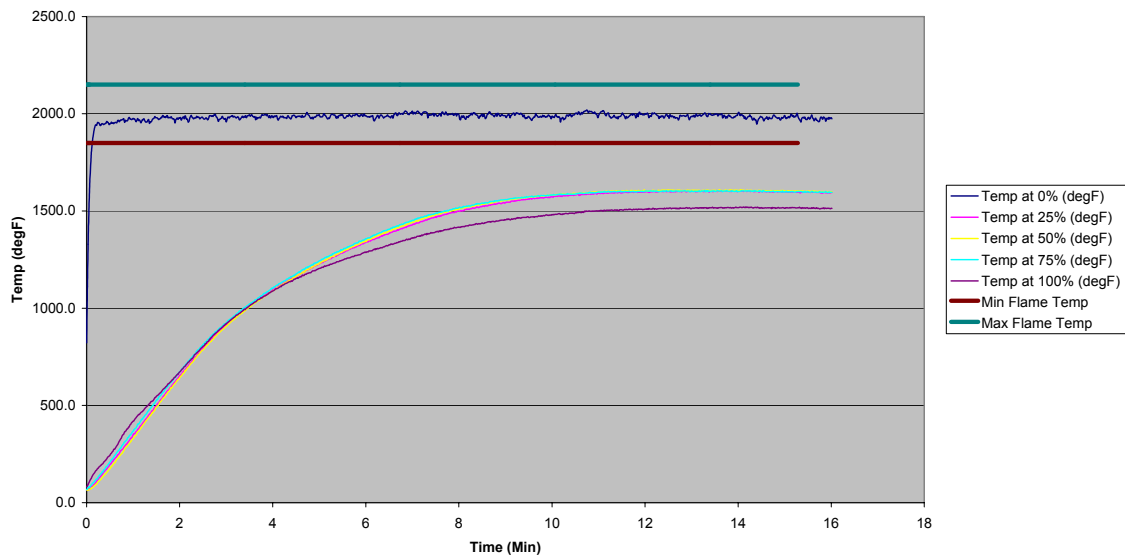

FIGURE 32. TIME-TEMPERATURE DATA DURING TEST 1 OF INCONEL 718

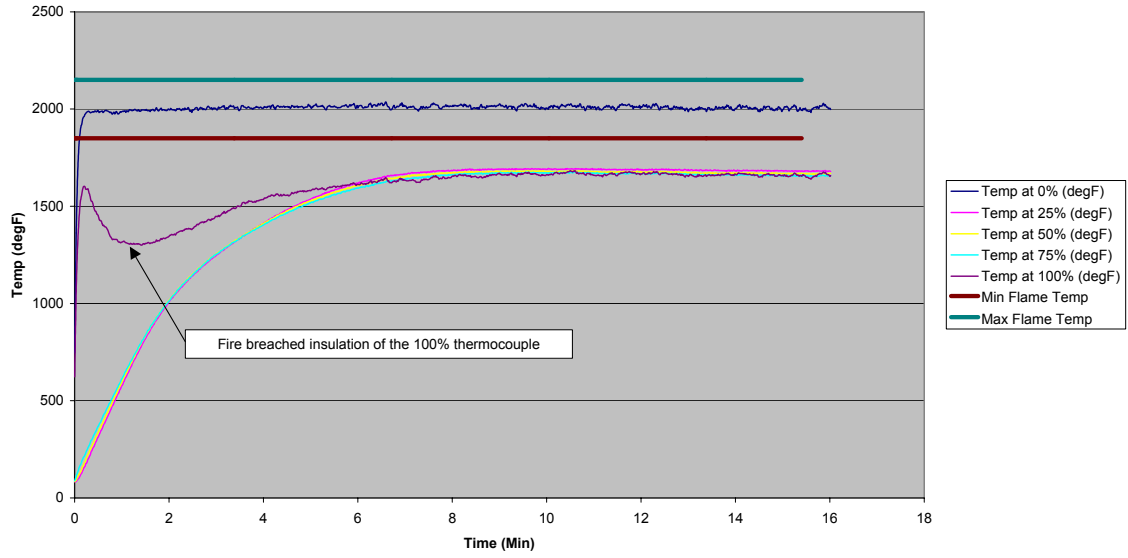

FIGURE 33. TIME-TEMPERATURE DATA DURING TEST 2 OF INCONEL 718

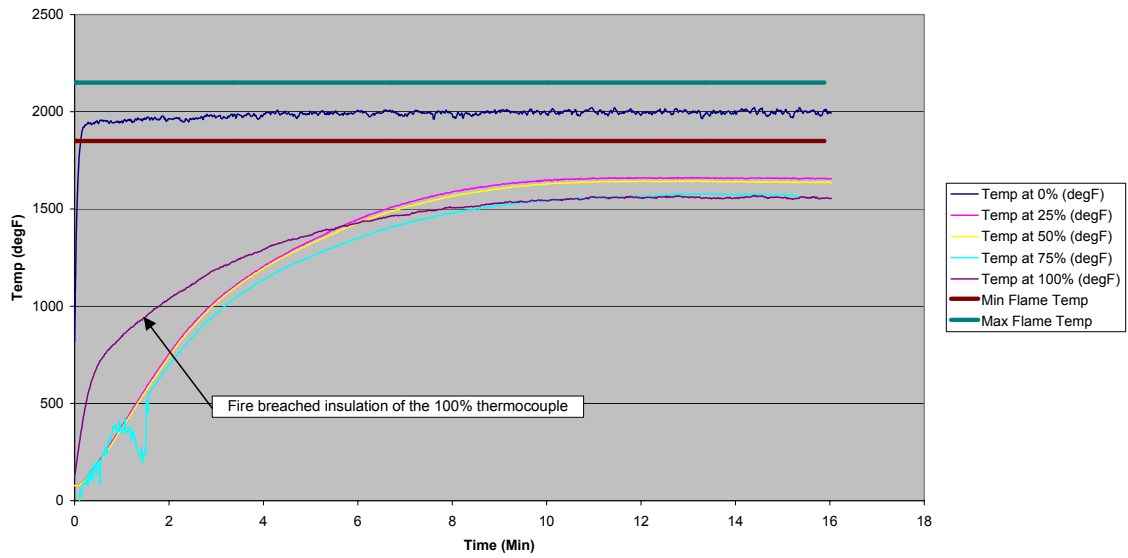

FIGURE 34. TIME-TEMPERATURE DATA DURING TEST 3 OF INCONEL 718

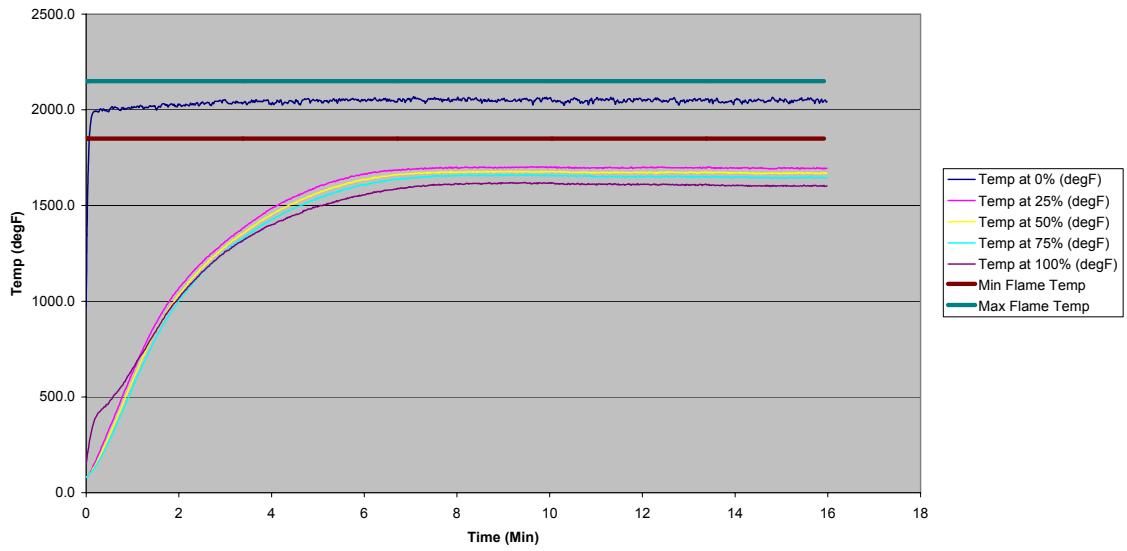

FIGURE 35. TIME-TEMPERATURE DATA DURING TEST 4 OF INCONEL 718



FIGURE 36. TEST FIXTURE DURING THE DETERMINATION OF THE SPECIMEN MAXIMUM DEFLECTION

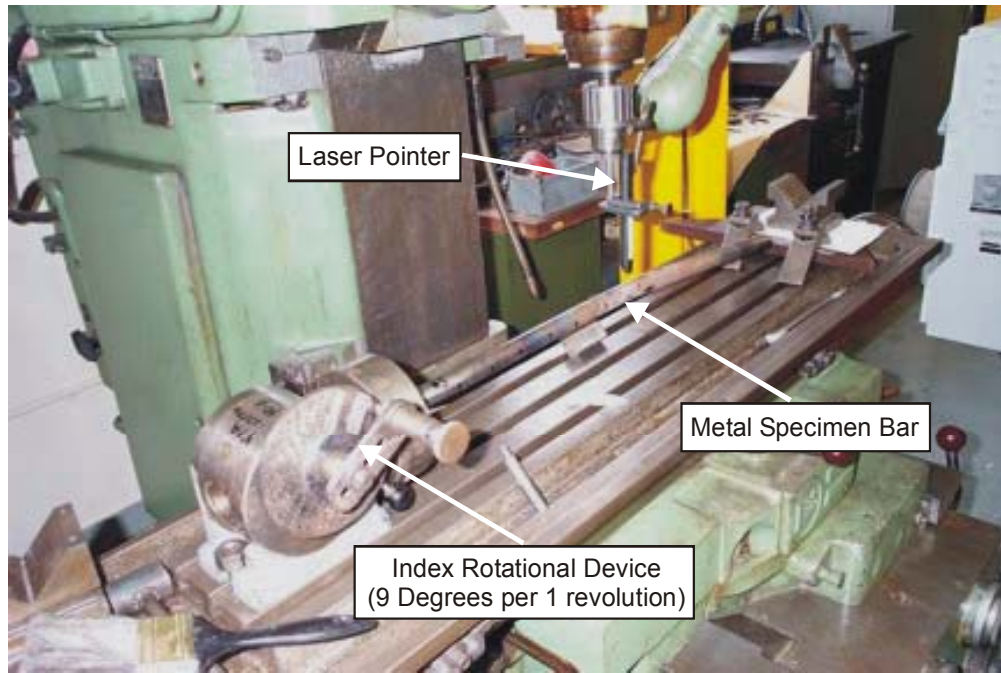
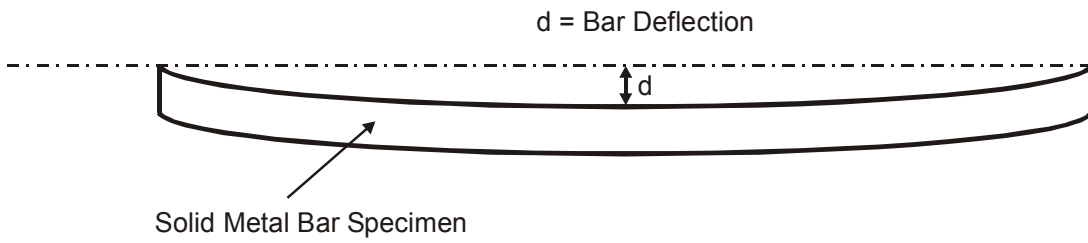
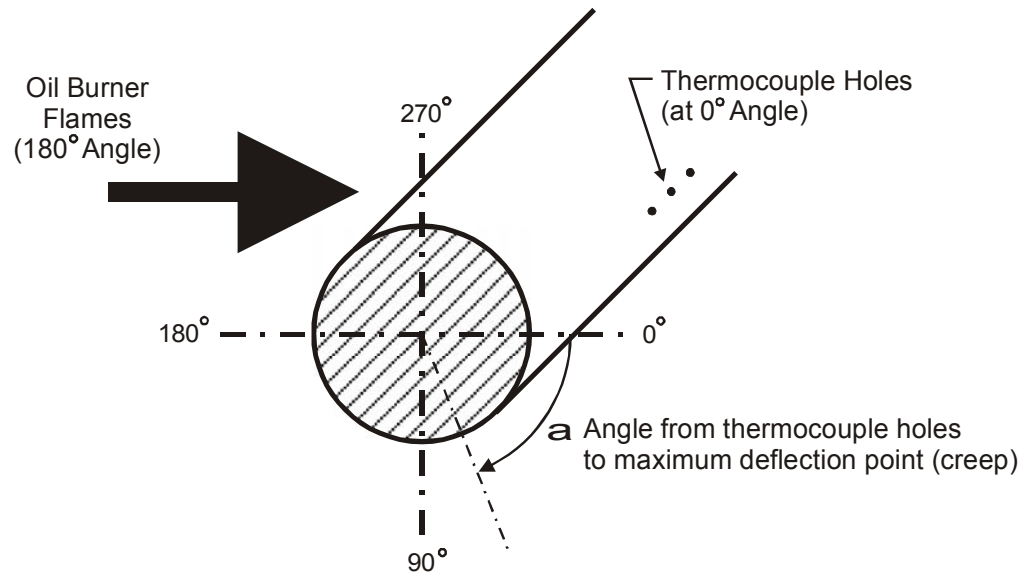

FIGURE 37. TEST FIXTURE DURING THE DETERMINATION OF THE SPECIMEN
MAXIMUM DEFLECTION ANGULAR LOCATION



(a) Illustration of Specimen Maximum Deflection



(b) Illustration of the Specimen Maximum Deflection Angular Location

FIGURE 38. SPECIMEN MAXIMUM DEFLECTION LOCATION

TABLE 1. TEST SPECIMEN DESCRIPTION

Material	Bar No.	Actual Length (in.)	Calculated Diameter (in.)	Actual Diameter (in.)	Actual Weight (lbs.)
Steel 4130					
	1	30.1	1.250	1.241	10.5
	2	30.1	1.250	1.245	10.5
	3	30.1	1.250	1.242	10.5
	4	30.1	1.250	1.241	10.5
	5	30.1	1.250	1.240	10.5
Steel 15-5PH					
	1	30.0	0.953	0.950	10.3
	2	30.0	0.953	0.955	10.3
	3	30.0	0.953	0.953	10.3
	4	30.0	0.953	0.952	10.3
	5	30.0	0.953	0.940	10.3
Aluminum 7075					
	1	30.0	1.286	1.275	3.9
	2	30.0	1.286	1.282	3.9
	3	30.0	1.286	1.280	3.9
	4	30.0	1.286	1.280	3.9
	5	30.0	1.286	1.278	3.9
Titanium 6Al-4V					
	1	30.0	0.938	0.931	3.2
	2	30.0	0.938	0.931	3.2
	3	30.0	0.938	0.935	3.2
	4	30.0	0.938	0.935	3.2
	5	30.0	0.938	0.935	3.2
Inconel 718					
	1	30.0	0.972	0.861	5.9
	2	30.0	0.972	0.861	5.9
	3	30.0	0.972	0.97	5.9
	4	30.0	0.972	0.861	5.9
	5	30.0	0.972	0.862	5.9

TABLE 2. SUMMARY OF RESULTS

Test Number	Test ID	Material	Temp (degF) AT 5 Minutes				Temp (degF) AT 15 Minutes				Comments		
			At 0% D	At 25% D	At 50% D	At 75% D	At 0% D	At 25% D	At 50% D	At 75% D		At 100% D	
1	052003T3	4130 Steel	2031.4	1319.6	1310.1	1305.9	1244.0	2049.8	1612.8	1609.5	1608.5	1555.1	
2	052103T1	4130 Steel	1878.0	1131.5	1094.5	1077.8	1038.5	1856.8	1562.9	1533.6	1516.4	1468.0	
3	052103T2	4130 Steel	1979.4	1273.5	1253.8	1231.9	1195.5	1955.1	1596.8	1577.3	1556.6	1513.4	
4	052203T2	4130 Steel	1848.4	1087.0	1029.4	1009.8	972.6	1892.3	1478.8	1430.9	1409.4	1376.6	
5	052903T1	4130 Steel	1789.1	1016.4	969.9	948.4	906.0	1792.9	1462.9	1417.0	1403.0	1365.0	Thermocouple at 0% reading low due to contact with bar.
6	060903T1	15-5PH Steel	1861.9	1126.4	1094.3	1068.6	1040.5	1876.0	1627.3	1602.0	1570.4	1499.0	
7	060903T2	15-5PH Steel	1926.8	1153.1	1128.4	1064.3	1097.3	1906.5	1641.4	1620.5	1560.4	1555.1	
8	061003T3	15-5PH Steel	1906.4	1114.8	1122.1	1125.1	1123.1	1900.4	1615.4	1612.1	1603.4	1543.5	
9	061003T4	15-5PH Steel	1925.9	1132.5	1096.4	1062.3	967.4	1898.0	1639.6	1613.3	1579.4	1472.5	
10	061003T5	15-5PH Steel	1905.3	1188.5	1146.0	1111.9	1041.6	1901.6	1633.4	1611.4	1583.9	1478.0	
11	061203T1	Titanium 6Al-4V	2003.4	1447.4	1439.9	1421.9	1360.4	2011.6	1644.9	1626.1	1608.6	1535.8	
12	061203T2	Titanium 6Al-4V	2003.6	1491.6	1447.6	1434.9	1365.6	1984.5	1707.3	1679.6	1658.8	1581.9	
13	061203T3	Titanium 6Al-4V	1978.5	1597.0	1557.9	1539.4	1470.5	1950.8	1679.3	1651.8	1635.3	1614.4	
14	061303T5	Titanium 6Al-4V	1999.0	1515.3	1519.5	1514.1	1512.0	1979.1	1637.4	1629.6	1628.5	1605.5	
15	061603T4	Titanium 6Al-4V	1937.9	1524.1	1517.5	1508.0	1484.1	1924.4	1653.0	1647.3	1638.6	1666.0	Aluminum bar started to melt after 5 minutes
16	080803T1	Aluminum 7075	1863.8	1099.1	1090.6	1085.6	1086.8	N/A	N/A	N/A	N/A	N/A	Aluminum bar started to melt after 5 minutes
17	080803T2	Aluminum 7075	1884.6	1121.3	1121.1	541.1	1136.6	N/A	N/A	N/A	N/A	N/A	Aluminum bar started to melt after 5 minutes
18	080803T3	Aluminum 7075	1967.8	1115.4	1105.1	1096.6	1207.8	N/A	N/A	N/A	N/A	N/A	Aluminum bar started to melt after 5 minutes
19	080803T4	Aluminum 7075	1965.3	1125.4	1123.5	1118.4	1173.3	N/A	N/A	N/A	N/A	N/A	Aluminum bar started to melt after 5 minutes
20	080803T5	Aluminum 7075	1804.4	1138.6	1137.4	1326.1	1360.9	N/A	N/A	N/A	N/A	N/A	Aluminum bar started to melt after 5 minutes
21	061703T1	Inconel 718	1995.3	1243.3	1232.8	1227.5	1204.6	1991.4	1599.5	1604.9	1599.3	1513.8	
22	071603T2	Inconel 718	2008.8	1516.9	1526.5	1536.5	1579.8	1997.4	1657.5	1668.4	1682.9	1659.9	
23	072103T3	Inconel 718	1999.1	1256.0	1321.9	1336.6	1365.0	1988.3	1576.9	1639.1	1659.1	1558.5	
24	072103T4	Inconel 718	2043.0	1537.9	1567.3	1599.8	1493.6	2050.4	1646.3	1666.1	1692.5	1604.5	
25	072903T5	Inconel 718	N/A	N/A	N/A	N/A	N/A	N/A	N/A	N/A	N/A	N/A	Test Aborted - Fire destroyed thermocouple connections

D = Diameter

TABLE 3. COMPARISON BETWEEN TEST DATA AND MIL-HANDBOOK-5H

Material	Average Temperature of 50% Diameter at 5 Minutes	MIL-Handbook-5H Data - UTS Percent Loss (%)	Average Temperature of 50% Diameter at 15 Minutes	MIL-Handbook-5H Data - UTS Percent Loss (%)	Comments
4130 Steel	1131.5	55	1513.7	Not able to compare	MIL-Handbook-5H (Figure 2.3.1.1.1) only shows data up to 1200degF, which results in a 64% loss of UTS (1/2-hour exposure to flame)
15-5 PH Steel	1117.4	Not able to compare	1611.9	Not able to compare	MIL-Handbook-5H (Figure 2.6.6.1.1) only shows data up to 800degF, which results in a 20% loss of UTS (1/2-hour exposure to flame)
Titanium 6Al-4V	1496.5	Not able to compare	1646.9	Not able to compare	MIL-Handbook-5H (Figure 5.4.1.1.1) only shows data up to 1000degF, which results in a 49% loss of UTS (1/2-hour exposure to flame)
Aluminum 7075	1115.6	100	N/A	N/A	MIL-Handbook-5H (Figure 3.7.4.1.1.c) only shows data up to 600degF, which results in a 89% loss of UTS (1/2-hour exposure to flame). Bar melted after 5 minutes of exposure.
Inconel 718	1412.1	50	1644.6	Not able to compare	MIL-Handbook-5H (Figure 6.3.5.1.1) only shows data up to 1480degF, which results in a 68% loss of UTS (1/2-hour exposure to flame).

TABLE 4. MATERIAL DEFORMATION INFORMATION

Material	Deformation Type	Maximum Deflection (in)*	Angular Location of Maximum Deflection (deg)	Comments
4130 Steel Bar 1	Crept	0.128	102	Angle measured clockwise from thermocouple holes on the bar.
4130 Steel Bar 2	Crept	0.132	131.46	Angle measured clockwise from thermocouple holes on the bar.
4130 Steel Bar 3	Crept	0.100	148.9	Angle measured clockwise from thermocouple holes on the bar.
4130 Steel Bar 4	Crept	0.358	133.06	Angle measured clockwise from thermocouple holes on the bar.
4130 Steel Bar 5	Crept	0.140	123.55	Angle measured clockwise from thermocouple holes on the bar.
Average 4130 Steel		0.172	127.794	Angle measured clockwise from thermocouple holes on the bar.
15-5PH Steel Bar 1	Crept	0.187	129.54	Angle measured clockwise from thermocouple holes on the bar.
15-5PH Steel Bar 2	Crept	0.177	138.28	Angle measured clockwise from thermocouple holes on the bar.
15-5PH Steel Bar 3	Crept	0.200	168.83	Angle measured clockwise from thermocouple holes on the bar.
15-5PH Steel Bar 4	Crept	0.128	144	Angle measured clockwise from thermocouple holes on the bar.
15-5PH Steel Bar 5	Crept	0.166	139.09	Angle measured clockwise from thermocouple holes on the bar.
Average 15-5PH Steel		0.172	143.948	
Titanium 6Al-4V Bar 1	Crept	0.485	238.91	Angle measured clockwise from thermocouple holes on the bar.
Titanium 6Al-4V Bar 2	Crept	0.360	227.18	Angle measured clockwise from thermocouple holes on the bar.
Titanium 6Al-4V Bar 3	Crept	0.748	225	Angle measured clockwise from thermocouple holes on the bar.
Titanium 6Al-4V Bar 4	Crept	0.376	234	Angle measured clockwise from thermocouple holes on the bar.
Titanium 6Al-4V Bar 5	Crept	0.790	233.46	Angle measured clockwise from thermocouple holes on the bar.
Average Titanium		0.552	231.710	
Aluminum 7075 Bar 1	Melted	N/A	N/A	N/A
Aluminum 7075 Bar 2	Melted	N/A	N/A	N/A
Aluminum 7075 Bar 3	Melted	N/A	N/A	N/A
Aluminum 7075 Bar 4	Melted	N/A	N/A	N/A
Aluminum 7075 Bar 5	Melted	N/A	N/A	N/A
Inconel 718 Bar 1	Crept	0.020	45	Angle measured clockwise from thermocouple holes on the bar.
Inconel 718 Bar 2	Crept	0.033	29.46	Angle measured clockwise from thermocouple holes on the bar.
Inconel 718 Bar 3	Crept	0.098	177.28	Angle measured clockwise from thermocouple holes on the bar.
Inconel 718 Bar 4	Crept	0.064	140.18	Angle measured clockwise from thermocouple holes on the bar.
Inconel 718 Bar 5	-	-	-	-
Average Inconel 718		0.054	97.980	Angle measured clockwise from thermocouple holes on the bar.

*Note: Deflection was measured from a horizontal line at the table to the maximum bend point on the bottom of the bar.