

DOT/FAA/AR-00/18

Office of Aviation Research
Washington, D.C. 20591

Development of Supplemental Inspection Report for the Fairchild Metro SA226 and SA227 Airplane

April 2000

Final Report

This document is available to the U.S. public
through the National Technical Information
Service (NTIS), Springfield, Virginia 22161.



U.S. Department of Transportation
Federal Aviation Administration

Technical Report Documentation Page

1. Report No. DOT/FAA/AR-00/18		2. Government Accession No.		3. Recipient's Catalog No.	
4. Title and Subtitle DEVELOPMENT OF SUPPLEMENTAL INSPECTION REPORT FOR THE FAIRCHILD METRO SA226 AND SA227 AIRPLANE				5. Report Date April 2000	
				6. Performing Organization Code	
7. Author(s) W. Dwyer				8. Performing Organization Report No.	
9. Performing Organization Name and Address Fairchild Aerospace P.O. Box 790490 San Antonio, TX 78279				10. Work Unit No. (TRAIS)	
				11. Contract or Grant No. DTFA03-96-C-00044	
12. Sponsoring Agency Name and Address U.S. Department of Transportation Federal Aviation Administration Office of Aviation Research Washington, DC 20591				13. Type of Report and Period Covered Final Report	
				14. Sponsoring Agency Code ACE-100	
15. Supplementary Notes The Federal Aviation Administration William J. Hughes Technical Center technical manager was Xiaogong Lee.					
16. Abstract This document is the final report covering the results of a 3-year program entitled "Development of a Supplemental Inspection Document for SA226/SA227 Aircraft." The program focused on developing a supplemental inspection document (SID) for all variants of the SA226 and SA227 based on damage tolerance analysis techniques. The SA226 and SA227 were designed and certified prior to the advent of modern damage tolerance analysis or FAR amendments, which require the aircraft structure to meet damage tolerance requirements. A major portion of this study consisted of collecting the data and performing the analysis necessary to establish an inspection program based on current damage tolerance methodology. Material and component tests, service experience, strain surveys, stress analysis, and fracture mechanics tools were all utilized to establish this program, which provides inspections and modifications necessary to help ensure the continued structural integrity of the airplane. These items were accomplished and the SID was developed.					
17. Key Words SA 226, SA227, Crack growth, Damage tolerance structural inspection, Metro, Merlin, SID			18. Distribution Statement This document is available to the public through the National Technical Information Service (NTIS) Springfield, Virginia 22161.		
19. Security Classif. (of this report) Unclassified		20. Security Classif. (of this page) Unclassified		21. No. of Pages 82	22. Price

TABLE OF CONTENTS

	Page
EXECUTIVE SUMMARY	vii
1. INTRODUCTION	1
1.1 Program Objectives	1
1.2 Aircraft Description	1
2. PHASE I TASKS	3
2.1 Identification of the Principal Structural Elements (PSE)	3
2.2 Identification of the Critical Areas of the Principal Structural Elements	4
2.2.1 Finite Element Models	5
2.2.2 Supporting Test Evidence	5
2.2.2.1 Strain Surveys	5
2.2.2.2 Fatigue Tests	5
2.2.3 Service Experience	5
2.2.4 PSE Critical Areas	7
2.3 Development of Stress Spectrum for Each Critical Area	9
2.3.1 Operational Statistics of the Fleet	9
2.3.2 Flight Profiles	10
2.3.2.1 SA227 Flight Profile Definition	10
2.3.2.2 SA226 Flight Profile Definition	12
2.3.3 Load Spectra Development	12
2.3.3.1 Gust and Maneuver Spectra	12
2.3.3.2 Taxi Spectrum	13
2.3.3.3 Landing Spectrum	14
2.3.4 Flight Strain Survey	14
2.3.5 Stress Spectra Development	15
3. PHASE II TASKS	15
3.1 Collect Material Property Data	15
3.1.1 Material Properties	15

3.1.2	Tensile Tests	15
3.1.3	Crack Growth Rate (da/dN) Tests	16
3.1.4	Fracture Toughness (K_c) Tests	16
3.1.5	Spectrum Loaded Coupon Tests	16
	3.1.5.1 Simple Coupon Tests	17
	3.1.5.2 Complex Coupon Tests	17
3.2	Establishment of Initial Flaw Sizes for Each Critical Location	18
	3.2.1 Primary Flaws	18
	3.2.2 Secondary Flaws	18
3.3	Determine Detectable Flaw Sizes for Each Critical Location	19
3.4	Perform Crack Growth Analysis for Each Critical Area	20
	3.4.1 Crack Growth Methodology	20
	3.4.2 Critical Crack Length and Residual Strength	20
3.5	Establish Supplemental Inspection Threshold for Each Critical Area	20
	3.5.1 Initial Inspections	20
	3.5.2 Fail Safety	21
	3.5.2.1 Fuselage Fail Safe Tests	21
	3.5.2.2 Wing Fail Safe Tests and Analysis	21
	3.5.2.3 Empennage Fail Safe Tests	21
	3.5.3 Fatigue Analysis	22
3.6	Establish Repeat Inspection Interval for Each Critical Area	22
3.7	Determine the Onset of Widespread Fatigue Damage	23
4.	PHASE III TASKS	24
5.	CONCLUSIONS AND RECOMMENDATIONS	24
6.	REFERENCES	25

APPENDIX A—DRAFT SUPPLEMENTAL INSPECTION DOCUMENT

LIST OF FIGURES

Figure		Page
1	SA227 Basic Geometry	3
2	SA227 Wing Finite Element Model	5
3	Strain Gage Locations	6
4	Locations of Critical Areas	8
5	Cruise Altitude Frequencies	9
6	Landings Per Hour Distribution	10
7	SA227 Flight Profiles	11
8	Gust and Maneuver Load Spectra	13
9	Sample Crack Detection Probability Curves	19
10	Inspection Interval and Crack Growth Curve Relationship	23

LIST OF TABLES

Table		Page
1	SA226 and SA227 Aircraft Performance	2
2	SA227-DC Basic Data	2
3	Principal Structural Elements (PSE)	4
4	PSE Critical Areas	7
5	Operational Statistics Summary	9
6	Metro III Mission Profile Selection	10
7	Metro II Mission Profile Selection	12
8	SA226 and SA227 Taxi Load Spectrum	14
9	SA226 and SA227 Landing Spectrum	14
10	Initial Flaw Size Assumptions	19
11	Detectable Flaw Sizes for the Cessna 402	20

EXECUTIVE SUMMARY

This document is the final report covering the results of a 3-year program entitled "Development of a Supplemental Inspection Document for SA226 and SA227 Aircraft." The program was funded through the Federal Aviation Administration (FAA) William J. Hughes Technical Center at the Atlantic City International Airport, NJ, under FAA contract number DTFA03-96-C-00044. The Fairchild SA226 and SA227 were selected by the FAA due to their relatively high percentage of aircraft in the regional airline fleet. The program focused on developing a supplemental inspection document (SID) for all variants of the SA226 and SA227 based on the latest damage tolerance analysis techniques.

The SA226 and SA227 were designed and certified prior to the advent of modern damage tolerance analysis or FAR amendments which require the aircraft structure to meet damage tolerance requirements. Therefore, a major portion of this study consisted of collecting the data and performing the analysis necessary to establish an inspection program based on current damage tolerance methodology. Material and component tests, service experience, strain surveys, stress analysis, and fracture mechanics tools were all utilized to establish this program which provides inspections and modifications necessary to help ensure the continued structural integrity of the airplane. These items were accomplished and the SID was developed in three phases.

Phase I of the SID development program consisted of three tasks:

1. Identification of the Principal Structural Elements (PSEs)
2. Identification of the critical areas of each PSE
3. Development of the stress spectrum for each critical area

Phase II of the SID development program consisted of seven tasks:

1. Collect material property data
2. Establish initial flaw sizes for each critical location
3. Determine detectable flaw sizes for each critical location
4. Perform crack growth analysis for each critical area
5. Establish supplemental inspection threshold for each critical area
6. Establish repeat inspection interval for each critical area
7. Determine time to onset of widespread fatigue damage

Phase III of the SID development program consisted of two tasks:

1. Publish the SID
2. Publish the final report (this document)

1. INTRODUCTION.

This document is the final report covering the results of a 3-year program entitled "Development of a Supplemental Inspection Document for SA226 and SA227 Aircraft." The program was funded through the Federal Aviation Administration (FAA) William J. Hughes Technical Center at the Atlantic City International Airport, NJ, under FAA contract number DTFA03-96-C-00044. The Fairchild SA226 and SA227 were selected by the FAA due to their relatively high percentage of aircraft in the regional airline fleet. The program focused on developing a supplemental inspection document (SID) for all variants of the SA226 and SA227 based on the latest damage tolerance analysis techniques.

1.1 PROGRAM OBJECTIVES.

The objective of this program was to establish supplemental structural inspections or modifications based on a state-of-the-art damage tolerance analysis, which further assure the safety and structural integrity of SA226 and SA227 aircraft in operation. The SA226 and SA227 designs were certified prior to FAR amendments requiring damage tolerant design and prior to the advent of modern damage tolerance analysis techniques. This program attempts to take full advantage of these developments by determining the crack growth life of critical areas of structure and then prescribing timely inspections or remedial structural modifications. Past work is not ignored in carrying out this process. Service history, previous fatigue tests, strain surveys, finite element analysis, and service bulletins all guide the analysis. New work has included material testing, additional strain measurements, and application of crack growth software. The structure has also been evaluated for susceptibility to widespread fatigue damage.

1.2 AIRCRAFT DESCRIPTION.

The Fairchild SA226/SA227 series aircraft have been in production since 1971. During that time approximately 800 have entered service. Meanwhile, the design has undergone extensive development to increase its economic usefulness. The maximum takeoff weight has grown from 12,500 lbs to 16,500 lbs. The high-time aircraft in the fleet now exceed 30,000 flight hours. It is expected that the present program will support continued safe operation to 50,000 hours.

The SA226 and SA227 are dual turboprop aircraft that can be configured for cargo, executive, or 19-seat commuter operation. Structurally there is little difference between the SA226 and SA227. The primary difference is that the SA227 wing is longer by 10 ft to support higher takeoff weights. Both models have a constant circular cross section fuselage which is 33 inches in radius and can be pressurized to 7 psi. Figure 1 depicts the basic geometry of the SA227 aircraft. Other important data are shown in tables 1 and 2.

TABLE 1. SA226 AND SA227 AIRCRAFT PERFORMANCE

Characteristic	SA226 Metro II	SA227 Metro III
Maximum Wt, lb	12,500	16,500
Wing Span, ft	46	57
Wing Area, ft ²	277	309
Type Propulsion Power per engine, hp	Twin-engine turboprop 840 shp dry 960 shp wet	Twin-engine turboprop 1000 shp dry 1100 shp wet
V _c at sea level, knots Design Cruising Speed	248	248
V _d at sea level, knots Design Dive Speed	311	311
N _m at V _c Maneuver Limit Load Factor	3.14	3.08
-N _m at V _c Maneuver Limit Load Factor	-1.26	-1.21
N _g at V _c Gust Limit Load Factor	3.14	3.08
-N _g at V _c Gust Limit Load Factor	-1.26	-1.21

TABLE 2. SA227-DC BASIC DATA

Characteristic	SA227-DC
Maximum Wt, lb	16,500
Wing Span, ft	57
Wing Area, ft ²	309
Type Propulsion Power per engine, hp	Twin-engine turboprop 1200 shp dry 1250 shp wet
V _c at sea level, knots Design Cruising Speed	248
V _d at sea level, knots Design Dive Speed	311
N _m at V _c Maneuver Limit Load Factor	3.08
-N _m at V _c Maneuver Limit Load Factor	-1.21
N _g at V _c Gust Limit Load Factor	3.08
-N _g at V _c Gust Limit Load Factor	-1.21

DATA	
<u>BASIC DIMENSIONS</u>	
LENGTH	59' 0"
HEIGHT	16' 8"
SPAN	57' 2"
<u>WING DATA</u>	
AREA:	
WING (TOTAL)	308.1 SQ FT
AILERON (TOTAL)	14.12 SQ FT
FLAP SLOTTED (TOTAL)	40.66 SQ FT
AIRFOIL:	
ROOT	NACA65 A215
TIP	MODIFIED NACA64 A415
ASPECT RATIO, AR	10.59
MAC	72.3 IN
SWEEP AT QUARTER CHORD	0.9 DEG
TAPER RATIO	.257
DIHEDRAL (WRP AT 32% CHORD)	5 DEG
ANGLE OF INCIDENCE:	
ROOT	+1 DEG
TIP	-2.69 DEG
GEOMETRIC TWIST	-3.69 DEG
<u>POWERPLANT DATA</u>	
ENGINES:	
TWO AIRESEARCH TPE331-12UA-701G (MAX CONT.)	1100 SHP
PROPELLERS:	
TWO 4 BLADED FULL FEATHERING	106 IN DIA
<u>LANDING GEAR DATA</u>	
MAIN GEAR (DUAL WHEELS)	
TOTAL STRUT STROKE	10 IN
TIRE (TUBELESS) 19.5 X 6.75-8, PLY RATING=10	
WHEEL	18 X 5.5
NOSE GEAR (DUAL WHEELS)	
TOTAL STRUT STROKE	8 IN
TIRE (TUBELESS) 18 X 4.4, PLY RATING=10	
WHEEL	18 X 4.4
<u>SPECIFICATIONS</u>	
WEIGHTS:	
TAKEOFF WEIGHT	16,500 LBS
EMPTY WEIGHT	8,680 LBS
LANDING WEIGHT	15,675 LBS
ZERO FUEL WEIGHT	14,500 LBS
<u>PERFORMANCE</u>	
SPEEDS:	
$V_{LO} = V_{LE} = 248$ KNOTS, CAS	
$V_{LO} = 311$ KNOTS, CAS	
MAX. OPERATING ALTITUDE	25,000 FT
<u>EMPELLAGE DATA</u>	
HORIZONTAL TAIL:	
AREA, TOTAL (INCLUDING FUSELAGE)	75.970 SQ FT
AREA, STABILIZERS (TOTAL)	54.7 SQ FT
AREA, ELEVATORS (TOTAL)	21.27 SQ FT
AIRFOIL SECTION:	
ROOT	MODIFIED NACA66A009
TIP	MODIFIED NACA63A009
INCIDENCE	VARIABLE
DIHEDRAL	0 DEG
VERTICAL TAIL:	
AREA, TOTAL (INCLUDING DORSAL)	56.0 SQ FT
AREA, (VERTICAL STABILIZER)	24.036 SQ FT
AREA, RUDDER	19.38 SQ FT
AREA, DORSAL FIN	10.583 SQ FT
AIRFOIL SECTION	
ROOT	MODIFIED NACA66A009
TIP	MODIFIED NACA63A009
AREA, VENTRAL	5.48 SQ FT

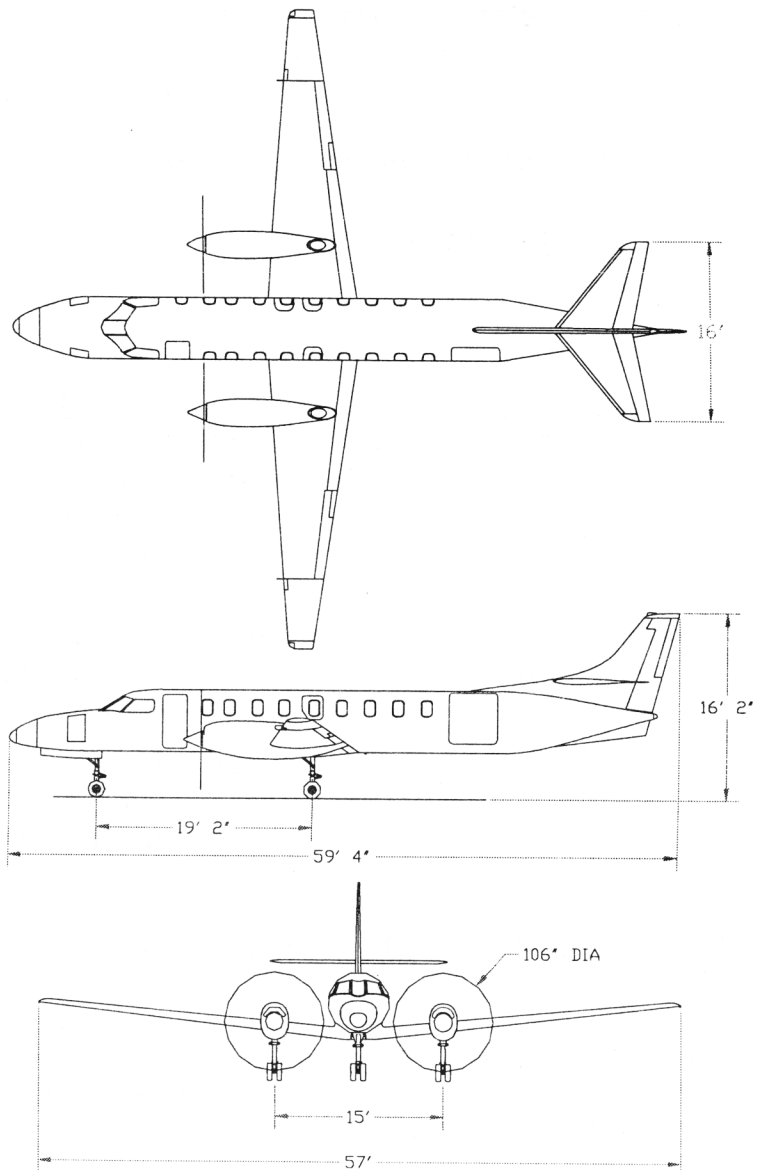

FIGURE 1. SA227 BASIC GEOMETRY

2. PHASE I TASKS.

2.1 IDENTIFICATION OF THE PRINCIPAL STRUCTURAL ELEMENTS (PSE).

A Principal Structural Element (PSE) is a structural element which contributes significantly to carrying flight and ground loads and whose failure, if it remained undetected, could lead to catastrophic failure of the airframe. Identification of these elements was made by considering components meeting one or more of the following criteria.

- Previous in-service or fatigue test difficulty
- High stress as shown by analysis or measurement

- Necessary for safe operation of the airplane
- Typically included as PSEs in SID development for other aircraft.

Table 3 lists the airframe components which were identified as PSEs.

TABLE 3. PRINCIPAL STRUCTURAL ELEMENTS (PSE)

Component	Structure
Wing	--Spar caps --Wing/fuselage attachment --Wing skin splices --Wing/tip extension attachment
Fuselage	--Quarter panel butt joints --Corners of window and door cutouts --Pressure bulkheads --Cargo door surround structure --Landing gear cylinders --Control column linkage
Empennage	--Horizontal stabilizer spar caps --Vertical stabilizer spar caps --Horizontal stabilizer pitch trim linkage
Engine Support Structure	--Engine mount truss/nacelle attachment --Nacelle longerons --Nacelle/wing attachment

2.2 IDENTIFICATION OF THE CRITICAL AREAS OF THE PRINCIPAL STRUCTURAL ELEMENTS.

A critical area of a PSE is one that will require specific action, such as special inspections or modifications in order to maintain continued airworthiness. Several criteria were used to select the critical areas of the principal structural elements:

- Areas subjected to relatively large cyclic stresses, as determined by finite element analysis or strain survey
- Areas with a history of cracking (usually due to local stress concentration) either in service or during fatigue testing
- Elements prone to corrosion
- Elements prone to accidental damage
- Hard to inspect elements

2.2.1 Finite Element Models.

The wing finite element model shown in figure 2 was used to analyze the SA227 wing [1]. The results were checked during the SA227 wing static test [2] and shown to be within about 1% of the measured stress for the more heavily loaded portions of the wing. The finite element model was therefore used as an aid for selecting critical PSE areas and determining stress at locations on the wing other than strain gage locations.

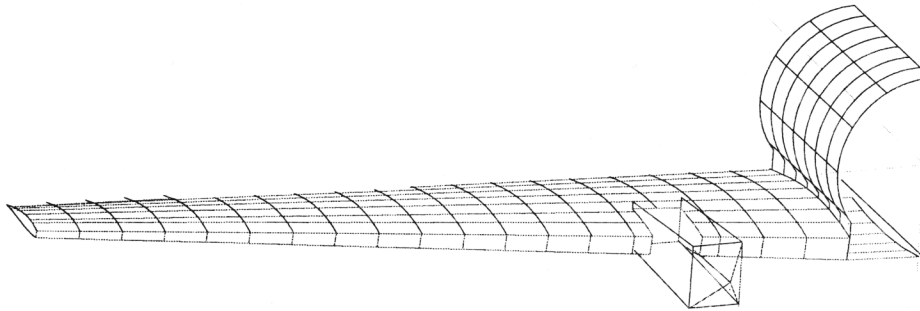

FIGURE 2. SA227 WING FINITE ELEMENT MODEL

2.2.2 Supporting Test Evidence.

2.2.2.1 Strain Surveys.

In support of the SID program, an SA227-DC aircraft was instrumented to measure strains at numerous locations during typical flight maneuvers. The details and results of these flight tests were reported at length in reference 3. Figure 3 shows the strain gage locations.

2.2.2.2 Fatigue Tests.

An SA226 airframe (excluding only control surfaces, engine mounts, and landing gear axles) was fatigue tested for 105,000 flight hours in 1979-80. The gust and maneuver spectrum applied was more severe than is actually experienced by aircraft operating today, as was discussed in reference 4. The results of the fatigue test were reported in reference 5. Results included documentation of the size, location, and time at discovery of fatigue cracks as well as measured static stresses at select locations on the airframe. This information was used to aid in the selection of the critical areas of the principal structural elements.

2.2.3 Service Experience.

Two sources of information on service experience of the aircraft were available to aid in selection of the critical PSE areas. These were service bulletins and FAA service difficulty reports.

Reference 3 lists the relevant structural service bulletins through 1997. Many of these bulletins resulted from findings of cracks in the structure. Areas of PSEs with a history of cracking

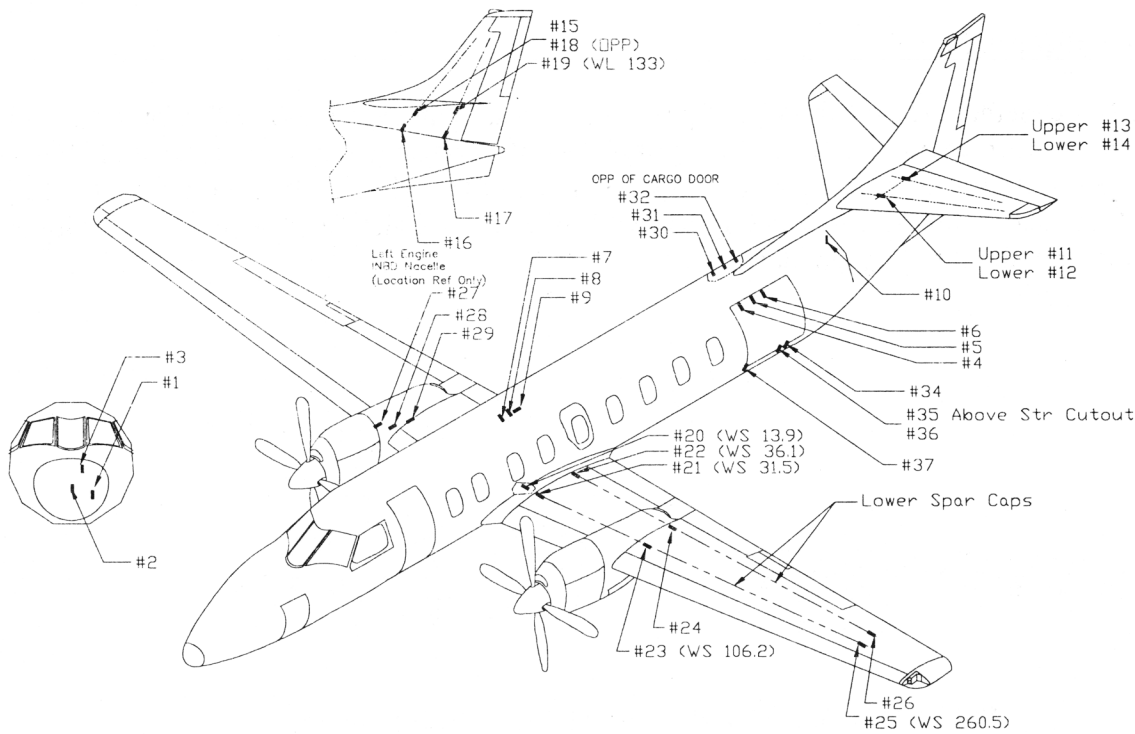

FIGURE 3. STRAIN GAGE LOCATIONS

covered by the service bulletins have been considered to be critical areas. These areas include the following:

- SA226 and SA227 Landing gear upper strut at drag brace boss
- SA226 and SA227 Ozone industries NLG and MLG aluminum yoke (housing) at valve installation hole
- SA226 and SA227 Passenger door opening corners
- SA226 and SA227 Cargo door belt frames at latch receptacles
- SA227 Horizontal stabilizer rear spar splice plate
- SA227 Lower wing skin and stringers at WS113 adjacent to aft inspection door

Reference 3 also lists the relevant findings of an ASAP database search of FAA difficulty reports for the period 1985 to 1997. Areas of PSEs with a history of cracking as shown by these reports were considered to be critical areas. These areas included the following:

- Cargo door hinge
- Keelson beam, angle, and web
- Landing gear upper strut at drag brace boss
- Nacelle upper longeron to wing skin attach angles
- Wing extension around attachment screw holes

2.2.4 PSE Critical Areas.

Table 4 presents the PSE critical areas selected for damage tolerance analysis. Figure 4 shows the locations of the critical areas. They are also depicted in reference 3.

TABLE 4. PSE CRITICAL AREAS

ID	Description
W1	SA226 Main spar lower cap @ WS 99.0
W2	SA226 Main spar lower cap @ WS 9.0
W3	SA226 Rear spar lower cap @ WS 27.0
W4	SA227 Main spar lower cap @ WS 99.0
W5	SA227 Skin splice lower surface @ WS 99.51
W6	SA227 Main spar lower surface wing tip extension fitting
W7	SA227 Lower wing skin on forward side of landing gear trunnion @ WS 113
W8	SA226 and SA227 Chordwise skin splice lower surface @ WS 173.944
W9	SA226 and SA227 Skin splice lower surface outboard of rib @ WS 27.103
W10	SA226 and SA227 Skin splice lower surface inboard of splice @ WS 27.103
W11	SA226 Wing skin lower center section at landing light cutout
W12	SA227 Rear spar lower surface wing tip extension fitting
W13	SA227 Rear spar lower surface at end of outboard extension fitting @ WS 270.12
W14	SA227 Main spar lower surface at end of outboard extension fitting @ WS 271.02
F1	SA226 T-stringer at top centerline near FS 330
F2	SA226 and SA227 Wing-fuselage forward attachment fittings
F3	SA226 and SA227 Wing-fuselage aft attachment fittings
F4	SA226 and SA227 Fuselage frame at fore/aft cargo door latches @ FS 454.5/455.7 and 473.4/474.6
F5	SA226 and SA227 Fuselage frame at fore/aft cargo door latches @ FS 455.7/473.4
F6	SA226 and SA227 Fuselage frame at cargo door sides
F7	SA226 and SA227 Cargo door hinge
F8	SA226 and SA227 Corners of passenger window cutouts
F9	SA226 T-stringer at bottom centerline aft of FS 362
F10	SA226 and SA227 Cargo door opening corners
F11	SA226 and SA227 Forward pressure bulkhead
F12	SA226 and SA227 Passenger door opening corners
F13	SA226 and SA227 Control column roller bearing
H1	SA226 and SA227 Rib strap at horizontal stabilizer rear spar @ BL 3.135
H2	SA226 and SA227 Horizontal stabilizer pitch trim actuator fittings
N1	SA226 and SA227 Nacelle upper longeron at firewall
N2	SA226 and SA227 Nacelle upper longeron at attachment to wing rib attach angles at main spar
N3	SA226 and SA227 Nacelle upper longeron to wing rib attach angles at wing rib
V1	SA226 and SA227 Vertical fin main spar cap strips at bottom of pivot fitting
EM1	SA227 Engine mount at firewall
LG2	SA226 and SA227 Landing gear cylinder 5453001-1,-3

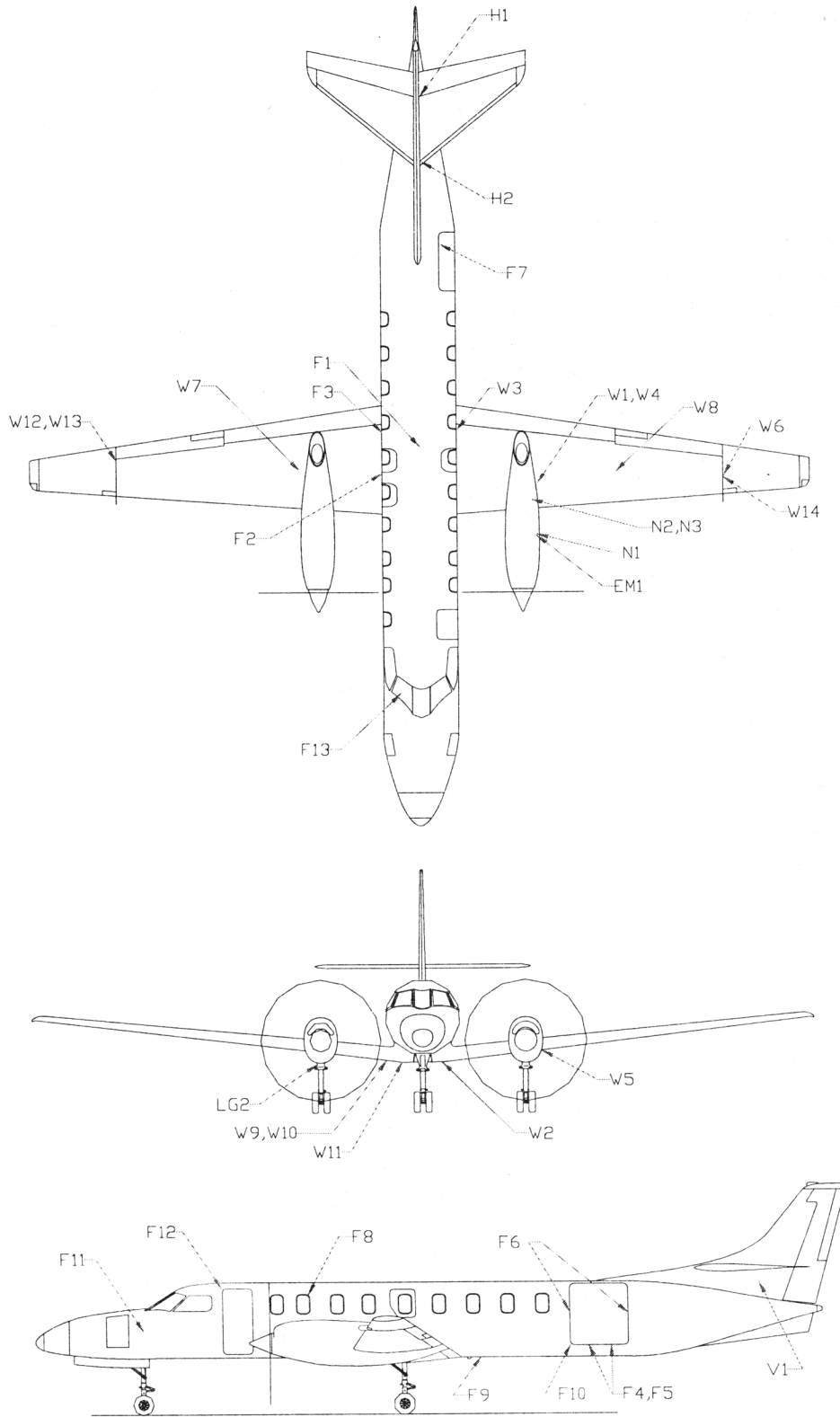

FIGURE 4. LOCATIONS OF CRITICAL AREAS

2.3 DEVELOPMENT OF STRESS SPECTRUM FOR EACH CRITICAL AREA.

2.3.1 Operational Statistics of the Fleet.

The SA226 and SA227 series aircraft are being operated in three types of service: scheduled commuter operation, executive transport, and cargo operation. Cargo operation has become more prevalent in recent years. Operators in each of these categories were surveyed to compile statistics on how their respective aircraft were used during periods of 1996-97. Additional information was gathered from the Official Airline Guide and teleconferences with the operators.

The surveys covered a total of 70 aircraft and 871 flights: 32 aircraft and 535 flights with two commuter operators, 31 aircraft and 248 flights with a cargo operator, and 7 aircraft and 190 flights with an executive operator. Table 5 and figures 5 and 6 summarize the findings of the surveys. The complete set of data is provided in reference 3.

TABLE 5. OPERATIONAL STATISTICS SUMMARY

Average Qty	Commuter	Cargo	Executive
Takeoff Fuel (lbs)	1,636	2,054	3,191
Landing Fuel (lbs)	1,103	1,109	1,803
Block Fuel (lbs)	532	945	1,388
Flight Fuel (lbs)	1,370	1,594	2,497
Block Time (hrs)	1.139	1.50	N/A
Flight Time (hrs)	0.968	1.32	1.98
Flight Distance (nm)	228	304	487
Flight Speed (kts)	234	227	244
Payload (lbs)	1,791	2,062	663
Landings/Hr	1.03	0.76	0.50
Cruise Altitude (ft)	16,778	19,827	17,463
Oper. Empty Wt (lbs)	9,525	9,206	10,831
Zero-fuel Wt (lbs)	11,594	11,268	11,594

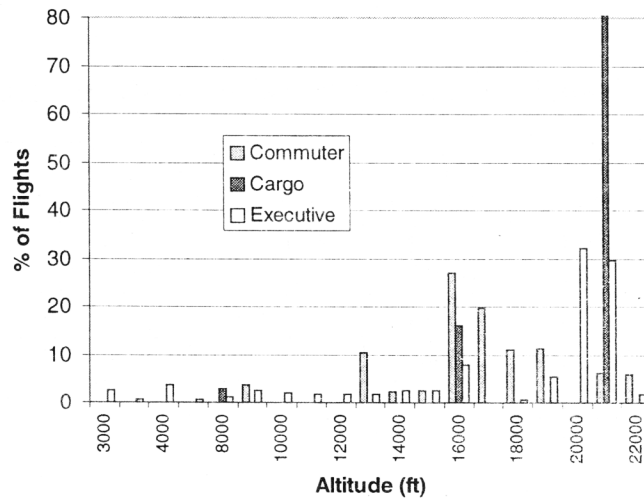

FIGURE 5. CRUISE ALTITUDE FREQUENCIES

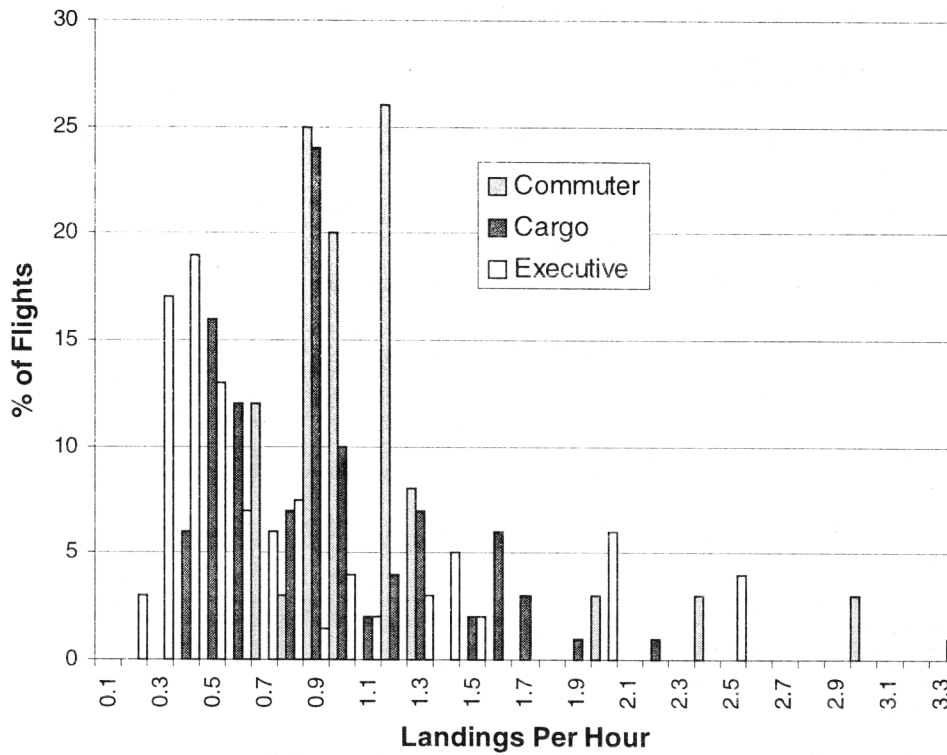

FIGURE 6. LANDINGS PER HOUR DISTRIBUTION

2.3.2 Flight Profiles.

2.3.2.1 SA227 Flight Profile Definition.

After reviewing the flight length, cruise altitude, and takeoff weight data of surveyed aircraft, three profiles were developed to represent flights typical of the three types of operation (commuter, cargo, executive). Table 6 shows the mission parameters and figure 7 illustrates the flight profiles.

TABLE 6. METRO III MISSION PROFILE SELECTION

Flight Profile Group	Flight Length (minutes)	Cruise Altitude (ft)	Gross Takeoff Weight (lbs)	Landing Weight (lbs)	Climb Speed (kts)	Descent Speed (kts)	Cruise Speed (kts)
Commuter	30	12000	12800	12500	160	220	250
Cargo	60	16000	13300	13000	160	220	250
Executive	120	20000	13800	12700	160	220	250

FLIGHT PROFILE - COMMUTER

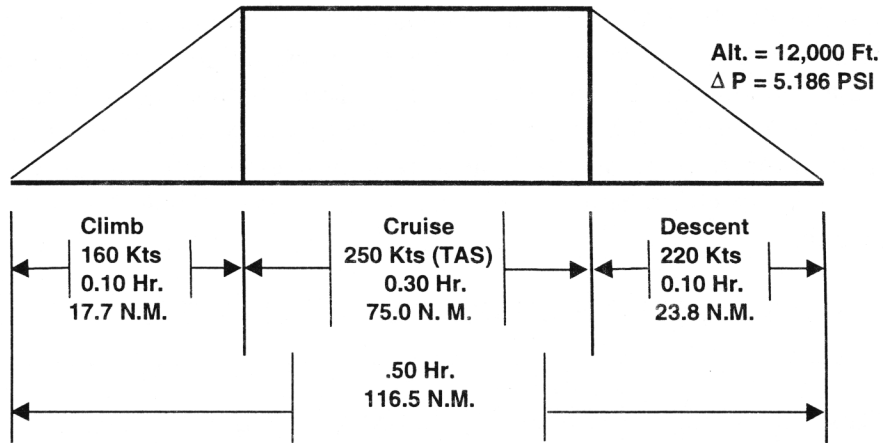

FLIGHT PROFILE - CARGO

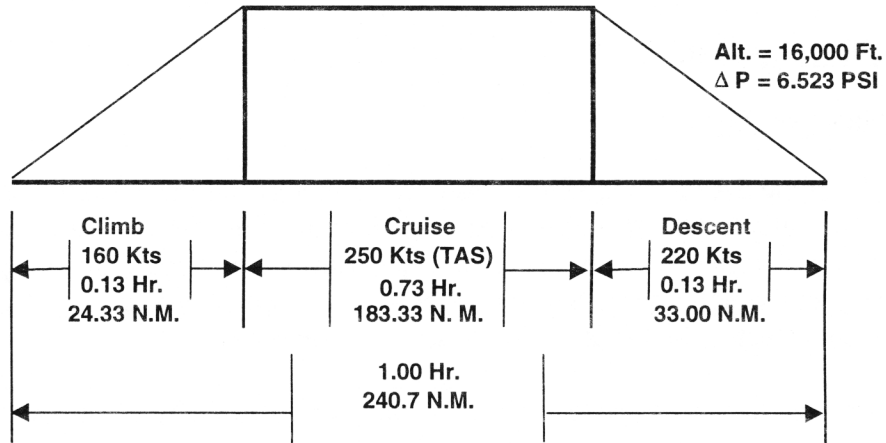

FLIGHT PROFILE - EXECUTIVE

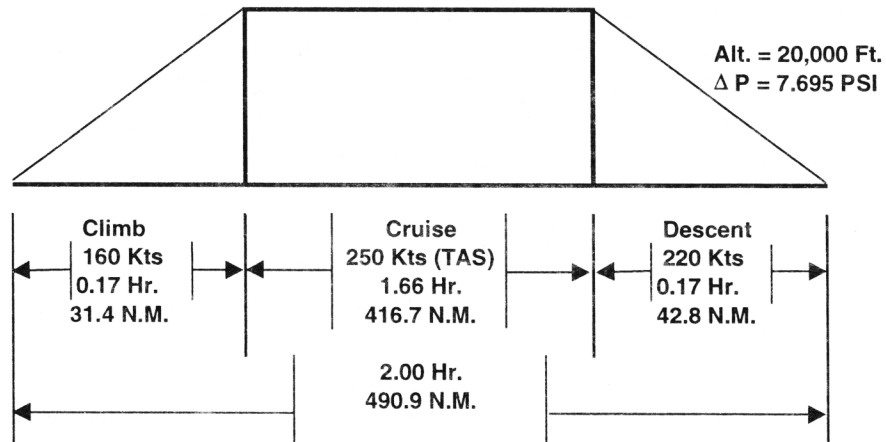

FIGURE 7. SA227 FLIGHT PROFILES

2.3.2.2 SA226 Flight Profile Definition.

The typical flight profile for the SA226 aircraft was taken from reference 2. This profile was developed in 1979 from operator surveys for use in the full-scale fatigue test. It represented the more severe usage that the aircraft received in their early lives. Adjustments were made to the spectrum at that time to account for the longer high altitude flights typical of executive transport missions. Most of the executive aircraft have since been converted to cargo operation, which tends to have a less severe spectrum because of longer stage lengths. Table 7 shows the SA226 mission profile selection.

TABLE 7. METRO II MISSION PROFILE SELECTION

Flight Profile Group	Flight Length (minutes)	Cruise Altitude (ft)	Gross Takeoff Weight (lbs)	Landing Weight (lbs)	Climb Speed (kts)	Descent Speed (kts)	Cruise Speed (kts)
Combined	30	20000	13800	13000	160	220	250

2.3.3 Load Spectra Development.

2.3.3.1 Gust and Maneuver Spectra.

The load spectrum from the SA226 fatigue test was used unchanged as the SA226 load spectrum for this program. The fatigue test spectrum was a modification of the spectrum presented in reference 6. The gust and maneuver portions of that spectrum were adopted unchanged but the flight length, altitude, and weights were adjusted to reflect the operational usage of the aircraft (the altitude adjustment affected the loads on the pressure vessel only).

The SA226 spectrum was not appropriate for use in analyzing the SA227 because the SA227 aircraft have operational profiles quite different than that of the aircraft used to define the reference 6 spectrum. In particular, the altitudes at which the aircraft are flown are quite different. A detailed analysis of the reference 6 spectrum was presented in reference 7. There it was seen that the pressurized general usage load spectrum was derived almost entirely from data collected on two similar aircraft operated a total of 1640 hours. The average altitude for the two aircraft was less than 11,000 feet. As this altitude is significantly less than altitudes reported by SA227 operators, a revised load spectrum was derived using the gust spectrum presented in references 8 and 9. This spectrum of gust velocities instead of gust loads allows one to construct a gust load spectrum based on the actual mission profiles flown by SA227 operators.

For each altitude, speed, and wing loading, a gust load spectrum was constructed using the atmospheric gust spectrum given in reference 8. The gusts encountered during climb and descent are accounted for by breaking these flight segments into several steps and calculating the appropriate gust frequency for each step.

To construct the spectrum an expansion of the reference 9 spectrum is used as a starting point. Each curve of exceedances per nautical mile is fit with a polynomial (quadratic or cubic depending on altitude) to develop an analytic expression for gust exceedances versus altitude.

The equations for gust load as a function of gust velocity given in FAR 23 were then used to generate specific gust loads for the gust velocities which occur at the mission profile flight conditions. The details of these calculations were presented in reference 3.

To validate the above procedure it was compared to the results of the load exceedance curve for pressurized aircraft given in figure 5 of reference 6. The referenced figure is dominated by data from two similar aircraft, whose physical and operational characteristics are given in Tables A-8 and B-7 of reference 6. For the referenced aircraft, the procedure used to obtain the SA227 load spectrum gives essentially the same spectrum as presented in reference 6.

Figure 8 shows the gust and maneuver load spectra for the SA226 and each of the three SA227 mission profiles.

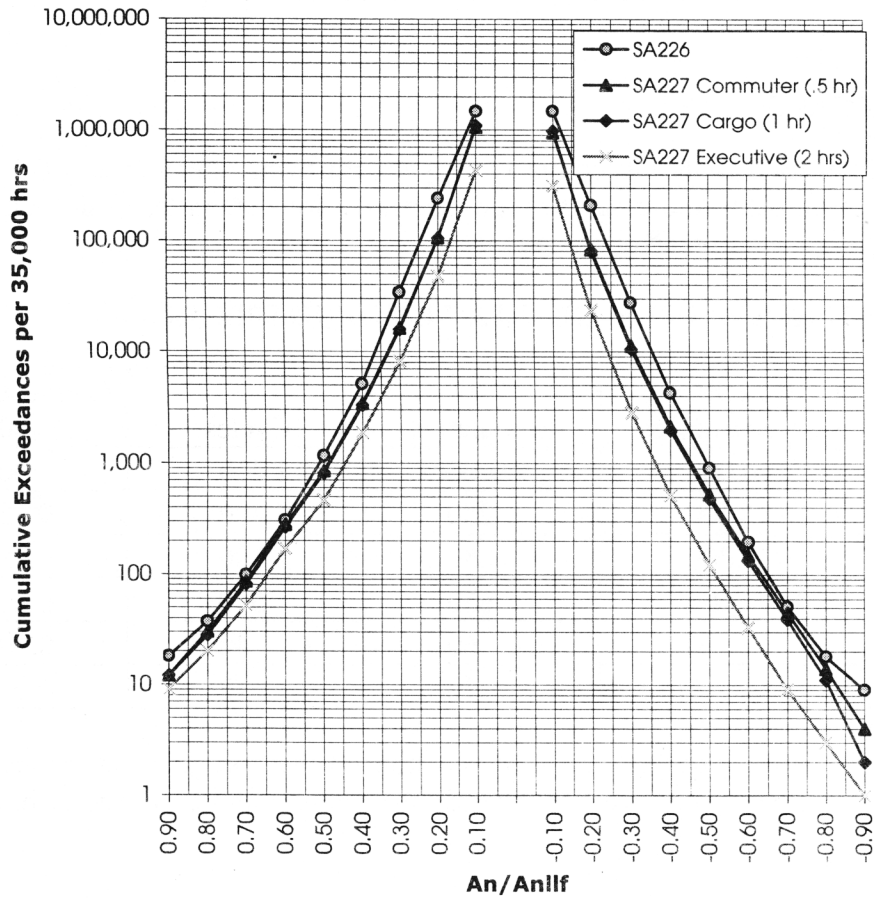

FIGURE 8. GUST AND MANEUVER LOAD SPECTRA

2.3.3.2 Taxi Spectrum.

The taxi spectrum in reference 6 was used to define the once per flight taxi bump. In most cases this load will result in the minimum G-A-G cycle stress. Table 8 shows the taxi load spectrum.

TABLE 8. SA226 AND SA227 TAXI LOAD SPECTRUM

G's	Cumulative Occurrences per 1000 landings	Cycles
1.00	500,000	--
1.30	2,000	1,900
1.40	100	90
1.46	10	10

Ninety-five percent of the landings will be followed by a 1.3-g taxi bump, 4.5% by a 1.4-g taxi bump, and 0.5% by a 1.46-g taxi bump. In addition, 40% of the taxi bumps will be assumed to occur with full fuel (1900 lbs per side). The high fuel load conditions are included to cover executive operations. This is excessive for commuter operations but could be used to substantiate a higher landing frequency per hour for commuter operations if that becomes necessary.

2.3.3.3 Landing Spectrum.

The landing spectrum used is the executive twin spectrum from reference 6. This spectrum, shown in table 9, is probably more severe than necessary for commuter airline operation but adequately covers cargo and executive operations.

TABLE 9. SA226 AND SA227 LANDING SPECTRUM

Sink Speed (fps)	Cumulative Occurrences	Test Cumulative	Cycles	Cumulative Per Landing
0	10,000	10,000	2,750	1.00
1	4,500	7,250	4,400	0.725
2	1,200	2,850	2,200	0.285
3	100	650	590	0.065
4	20	60	48	0.006
5	5	12	12	0.0012

While performing the crack growth analyses it was noticed that the gust and maneuver spectra had the most effect on the rate of growth; whereas the landing and taxi spectra had relatively little effect.

2.3.4 Flight Strain Survey.

Figure 3 in section 2.2.2.1 showed the locations of strain gages used to measure stresses on the aircraft during typical flight maneuvers. This data was used to help transform flight loads to stresses at critical areas of the principal structural elements. Further discussion of the methods and results of the strain survey is available in reference 3.

2.3.5 Stress Spectra Development.

The load spectrum gives the accelerations experienced by the aircraft c.g. during various phases of flight. For each critical area the accelerations were converted to stresses using a transfer factor obtained from the flight strain survey and finite element analysis. For example, strain gage data might be available a few inches away from a critical location at a variety of load conditions. A finite element model could then be used to obtain the stress at the critical location, using the gross stress a few inches away as input. Throughout the analysis a linear stress-load relationship was assumed.

3. PHASE II TASKS.

3.1 COLLECT MATERIAL PROPERTY DATA.

3.1.1 Material Properties.

After determining the load spectrum of each PSE, the next step in the damage tolerance analysis was to locate the appropriate material properties to use for crack growth analysis. The crack growth computer program, NASA/FLAGRO (“NASGRO”), version 2.0, contained the necessary material properties for all but three of the PSE materials. The three exceptions were (1) 4130N tube, used in the engine mount truss; (2) 2024-T42 sheet, used in certain areas of the nacelle and empennage; and (3) 2014-T6511 extrusion, used in the wing spar caps, wing stringers, and fuselage T-stringers.

For 4130N, a crack growth database was obtained by modifying the NASGRO database for 160-180 UTS 4340 steel by inserting representative yield and ultimate strength values for 4130N from MIL-HNDBK-5G. This was justified by noting the strong dependence of K_{Ic} and ΔK_{I0} on yield strength of AISI 4XXX series steels. For analysis of cracks in 2024-T42, the NASGRO database for 2024-T3 T-L plate was used because tests from reference 10 showed 2024-T3 to have a higher crack growth rate at typical crack lengths.

The wing spar caps and stringers are highly stressed and difficult to inspect. For these reasons, extensive testing of 2014-T6511 extrusion from Fairchild stocks was carried out by Southwest Research Institute to determine the crack growth properties of this material. Complete documentation of the test procedure and results can be found in reference 4. However, the following sections summarize what was accomplished.

3.1.2 Tensile Tests.

Seven rectangular tensile specimens were machined from 2014-T6511 extrusion blanks and tested per ASTM E8-96a. For all seven specimens, the values of yield strength and tensile strength extracted from the stress-strain curves met or exceeded MIL-HNDBK-5G values. Elongation and elastic modulus of the specimens also exceeded handbook values by a significant margin.

3.1.3 Crack Growth Rate (da/dN) Tests.

Eleven specimens were constructed of 2014-T6511 extrusion from Fairchild stocks and tested according to ASTM E647-95a. Several different types of specimens were tested, including middle crack tension, compact tension, and eccentrically loaded single edge crack tension specimens. Loads were controlled by the “K-control method” described in the ASTM standard, and crack length was measured by both traveling optical microscope and nonvisual (KRAK) gage. All specimens were tested in the L-T orientation since this is the orientation in which the extrusions in the aircraft are loaded. Growth rate curves were obtained for stress ratios (R ratios) of - 0.2, 0.2, 0.5, and 0.8.

The objective of the crack growth rate tests was to obtain constants for use in the NASGRO crack growth equation, since NASGRO does not have constants for 2014-T6511 extrusion. To accomplish this the existing NASGRO constants for 2014-T6 plate were adjusted so that the NASGRO crack growth equation matched the experimental crack growth data for the 2014-T6511 extrusion as closely as possible. Reference 4 contains details of this curve-fitting process.

The tests demonstrated that over a wide range of R ratios, NASGRO analysis predicts the life of the crack growth test specimens to within a factor of 2. This is considered good accuracy for currently available fracture mechanics technology.

3.1.4 Fracture Toughness (K_{Ic}) Tests.

Fracture toughness tests were carried out on four compact specimens per ASTM E399-90 in order to verify the NASGRO values of fracture toughness (K_{Ic}). Fracture toughness is important in the NASGRO analysis because one of the criteria for part failure is whether the maximum stress intensity has exceeded the fracture toughness. If so, then the part fails.

The average fracture toughness of the 2014-T6511 extrusion samples was 40 ksi $\sqrt{\text{in}}$. This compares to a value of 51.8 for NASGRO 2014-T6 plate. This difference was not significant to the crack growth analysis, however, because after the crack grew close to its critical size the stress intensity grew from a small value (less than 10 ksi $\sqrt{\text{in}}$) to a large value (greater than 50 ksi $\sqrt{\text{in}}$) in only a few hundred flight hours. Therefore failure occurred at about the same time whether the fracture toughness was 40 or 51.8 ksi $\sqrt{\text{in}}$.

3.1.5 Spectrum Loaded Coupon Tests.

Spectrum loaded coupon tests were carried out to determine whether the spectrum causes any load interaction (retardation) effects in the material and to further validate the crack growth analysis method (NASGRO). Two types of coupons were tested: (1) a simple coupon, consisting of a rectangular plate of 2014-T6511 with a single offset fastener hole, and (2) a complex coupon, consisting of a fastened assembly of 2014-T6511 and titanium plates to simulate the geometry of critical area W1. The thickness, width, and fastener locations of all sections were as close as possible to those in the aircraft, within the constraints of the coupon testing apparatus.

3.1.5.1 Simple Coupon Tests.

The primary function of the simple coupon tests was to establish the validity of the crack measurement technique to be used in the complex coupon tests where the crack was not visible. The simple coupon also provided validation of the relevant NASGRO analysis case, TC03. Two coupons were tested.

Each simple coupon was inflicted with a 0.025 inch lateral electrodynamically machined slit (EDM) through-cut in the fastener hole. Prior to beginning the spectrum loading this cut was precracked an additional 0.025 inch to ensure realistic behavior. The precracking was accomplished by applying blocks of constant-amplitude loading at relatively low load levels. After the spectrum loading commenced, the crack length was measured with KRAK gages as well as by the markerband method.

The lives of the two coupons deviated from each other by nearly 50%. This is explained by noticing that the grain structures of the two coupons were markedly different. The growth curve of the coupon having the more typical grain size was compared to the growth curve predicted by the NASGRO TC03 model with constants from the da/dN tests. The curves showed excellent agreement, providing validity to use of the NASGRO model without retardation. An analysis of these results, with photographs of the microstructures, is provided in reference 4.

3.1.5.2 Complex Coupon Tests.

Three complex coupons were tested under spectrum loading, each with a precrack of approximately 0.050 inch in one of the fastener holes just prior to the end of the titanium strap. This location has the most severe stress as predicted by the finite element model.

Each complex coupon was fitted with eight strain gages to verify that the desired stress was achieved and to measure the degree of bending and load transfer by the fasteners. Strain readings were taken at 85% of peak load. Results showed that at the midsection of the coupon, the bending was approximately 18% of the average stress. Further, the load transferred to the titanium plates by the last fastener was 35-40 percent of the applied load. This is consistent with the results of the finite element model used to determine the fastener loads for NASGRO crack growth analysis.

Each of the three coupons was subjected to spectrum loading until the short ligament completely failed. As was the case in the simple coupon tests, the lives of the complex coupons varied considerably. The shortest and longest lives differed by a factor of 2. However, the NASGRO analysis showed good agreement with the shortest coupon life, again validating the use of the NASGRO model without retardation.

Both the simple and complex coupon tests demonstrated that the NASGRO analysis method gives realistic but conservative results.

3.2 ESTABLISHMENT OF INITIAL FLAW SIZES FOR EACH CRITICAL LOCATION.

In contrast to fatigue life analysis, modern crack growth analysis assumes the pre-existence of flaws in the material at critical areas of the structure. The size of these flaws when the total airframe time is zero determines their growth rates as the airframe ages. A conservative damage tolerance analysis, therefore, must assume the worst case initial flaw at each critical location in the airframe.

The initial (pre-existing) flaw shapes, sizes, and orientations assumed for the damage tolerance analysis are presented in this section. The flaws are intended to provide the basis for analytical crack growth predictions to determine the initial and repeat inspection requirements for the aircraft.

The initial flaws are classified as either primary or secondary flaws. Primary flaws provide the primary crack initiation site in a part and are representatives of gross manufacturing defects that have escaped detection by quality control. Secondary flaws provide crack initiation sites for continued growth after primary growth has been arrested by the edge of the part or an adjacent hole. Secondary flaws are representative of typical manufacturing quality.

3.2.1 Primary Flaws.

Initial (primary) flaws are assumed to exist in the aircraft from the time of manufacture. These flaws, along with their subsequent growth under flight conditions, will establish the initial inspection times for the aircraft based on crack growth. The initial flaws are assumed to exist at holes, edges of cutouts, edges of parts, or at the most unfavorable location with respect to the applied stress and material properties. The initial flaw size is the same regardless of whether the crack originates at a hole or at the edge of the part. These flaws will be quarter-circular corner cracks except when the part thickness is less than or equal to the flaw size, in which case the flaw will be a through-the-thickness crack. The initial cracks will be assumed to start from the side of the hole nearest the edge of the part (when an edge is present). The initial flaw sizes, based on AFGS-87221A [11], are shown in table 10. Only a single primary flaw will be assumed to exist at each location analyzed.

3.2.2 Secondary Flaws.

Secondary flaws will be assumed to grow independently of the primary flaw up to the point when the primary flaw induces a failure. During the time it takes a primary flaw to grow from a fastener hole to the edge of the part (ligament failure), a secondary flaw will be assumed to be growing opposite the primary flaw. At failure of the ligament, the continuing damage will include the growth of the secondary crack. For multiple load path members, after failure of the member which contains the assumed primary flaw, the remaining members must have enough residual strength to support the load in the presence of a secondary flaw that has grown during the time it took the primary flaw to terminate. The secondary flaw sizes for all structure are shown in table 10.

TABLE 10. INITIAL FLAW SIZE ASSUMPTIONS
From Reference 10

Flaw Location	Material Thickness (in)	Primary Flaw	Secondary Flaw
Hole or Edge	≤ 0.05	0.05 inch through the thickness	0.005-in-deep × 0.005-in-wide corner
Hole or Edge	> 0.05	0.05-in-deep × 0.05-in-wide corner	0.005-in-deep × 0.005-in-wide corner

3.3 DETERMINE DETECTABLE FLAW SIZES FOR EACH CRITICAL LOCATION.

The detectable crack length and the probability of detection are affected by a number of factors. These factors include human factors, inspection method, instrument calibration, structural geometry, and accessibility. The objective is to define an inspection method that ensures that sufficiently small cracks will be detected with a 90% probability at a 95% confidence level. It is recommended that an NDI technician that is certified to a minimum of Level II in the applicable inspection method, as defined by the American Society for Nondestructive Testing Recommended Practice, Number SNT-TC-1A, be required for performing these inspections.

It is important to realize that although an instrument may have very high quoted sensitivity, the sensitivity in the actual installation may be significantly less. An evaluation of the minimum detectable crack length must be made for each type of installation to be inspected. It is also important not to overestimate the minimum detectable crack length by too much, as this could lead to unnecessarily frequent and costly repeat inspections.

Figure 9, reproduced from reference 12 page 4-85, shows probability of detection for uncovered flaws in thin aluminum. Table 11 lists quoted minimum detectable crack sizes from specific installations in the Cessna 402 [13]. Reference 14 gives the following formula for detectable crack size of surface eddy-current probes: Detectable Crack Length = (Fastener Head DIA – Fastener Shank DIA) / 2 + Coil DIA

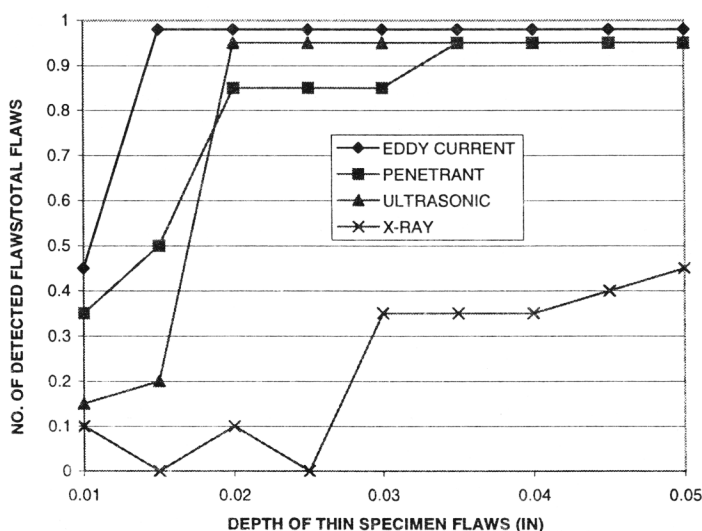

FIGURE 9. SAMPLE CRACK DETECTION PROBABILITY CURVES

TABLE 11. DETECTABLE FLAW SIZES FOR THE CESSNA 402

NDI Method	Detectable Flaw Size (in)
Surface Eddy Current	0.10 - 0.16
Visual	0.25
Magnetic Particle	0.10
Florescent Penetrant	0.10
Bolt Hole Eddy Current	0.08

3.4 PERFORM CRACK GROWTH ANALYSIS FOR EACH CRITICAL AREA.

3.4.1 Crack Growth Methodology.

All crack growth analysis was performed using NASGRO version 2.0. This version does not account for retardation. For an explanation of the methodology used in NASGRO, see reference 15.

3.4.2 Critical Crack Length and Residual Strength.

As a crack grows in a loaded member, eventually the crack reaches a size at which the member can no longer support limit load. At this point limit load causes fracture of the member. The crack length at which this occurs is defined as the critical crack length. The residual strength of the member at this crack length is equal to limit load.

In establishing an inspection program it is desired to discover cracks in the structure before they reach critical length. The critical length and the time at which it occurs can be determined directly from crack growth analysis if the load spectrum contains at least one application of limit load per simulated flight. (This load can be applied during a fictitious fractional cycle in the load spectrum.) In such cases the critical length is simply the length at whichever of the following conditions occurs first: (1) unstable crack growth (vertical crack growth curve) when the maximum stress intensity factor (K_{max}) equals the fracture toughness (K_c) or (2) the net section stress equals the material ultimate strength. In NASGRO, the average of the yield and ultimate strengths is used in place of the ultimate strength.

3.5 ESTABLISH SUPPLEMENTAL INSPECTION THRESHOLD FOR EACH CRITICAL AREA.

3.5.1 Initial Inspections.

The time to initial inspection (also termed the inspection threshold) is determined for most critical areas by the time T_{crit} for an initial flaw to grow to critical size. In these cases a scatter factor, SF1, is applied as recommended by FAA Draft AC-91-XX. A scatter factor of 2 is used when there is no full-scale fatigue test data and no load substantiation through a flight and ground loads survey. A factor of 1.5 is used when there is either fatigue test data but no load survey, or a load survey but no fatigue test data. A factor of 1 is used when there is fatigue test

data and a load survey. The initial inspection thus occurs after the following number of hours have elapsed:

$$\text{Initial Inspection} = T_{\text{crit}} / \text{SF1}$$

The inspection thresholds for the remaining critical areas were determined by fatigue test results or were adopted from existing inspection documents such as the Airframe Airworthiness Limitations Manual. All initial inspection times are given in the SA226 and SA227 SID, reference 13.

3.5.2 Fail Safety.

3.5.2.1 Fuselage Fail Safe Tests.

As reported in reference 5, after 98,000 hours of the SA226 full-scale fatigue testing, a small saw cut was made in the T-stringer at the fuselage crown. The growth of this crack was monitored. At the completion of the test, the saw cut was extended to 5 inches along the stringer and the full 7 psi cabin pressure was applied without failure.

A saw cut was also made at 98,000 hours in the two most highly stressed hat channels on the forward pressure bulkhead. These cracks were allowed to grow to the end of the test at which time the full pressure load was applied without failure.

The fail safety of the cargo door latching system was substantiated by removing one of the click-clack latches and subjecting the remaining latches to 15 cycles of full pressurization. The remaining latches held the door without failure.

3.5.2.2 Wing Fail Safe Tests and Analysis.

Complete fail safety analyses were carried out for the SA226 and SA227 wings for certification [ref 2 fail safety reports]. These analyses showed that failure of any one element of the forward or rear spar caps would not cause total failure of the wing at limit load. This was also shown by test during the SA226 full-scale fatigue test. At 98,000 hours of the test, 0.050-inch saw cuts were made through the depth of the main spar cap at fastener holes at stations 9 and 99. Since the simulated cracks did not grow, they were artificially extended at the end of the test and subjected to limit load without failure.

3.5.2.3 Empennage Fail Safe Tests.

When the initial saw cuts were made in the wing and fuselage, similar cuts were made in the empennage. A cut was made in the vertical tail main spar at about waterline 130. The cut was made in a fastener hole, in the direction away from the spar web, and was long enough to extend beyond the fastener head so that it could be monitored for the remainder of the test. A saw cut was also made in the horizontal stabilizer rear spar at about butt line 20. This cut was made in the last fastener hole where the strap at that location ends, in the direction away from the spar web, and was long enough to be observed during the remainder of the test. Both saw cuts were

extended at the end of the fatigue test and subjected to limit load. Neither of the simulated cracks caused failure.

3.5.3 Fatigue Analysis.

Fatigue analysis, such as by Miner's Rule, was not used in developing the SID. However, this type of analysis did form the basis of some of the inspection thresholds listed in the Airframe Airworthiness Limitations Manual.

3.6 ESTABLISH REPEAT INSPECTION INTERVAL FOR EACH CRITICAL AREA.

The repeat inspection interval is the time that may safely elapse between the threshold inspection and the next inspection of a PSE. For critical areas of PSEs analyzed for crack growth, the repeat inspection interval depends on three quantities:

- a. The time, T_{det} , for an initial flaw to grow to the maximum undetectable flaw size. The maximum undetectable flaw size is unique for each critical area and was discussed in section 3.2.
- b. The time, T_{crit} , for an initial flaw to grow to the critical flaw size. The critical flaw size is the flaw size beyond which the part can no longer sustain application of limit load without failure.
- c. An appropriate scatter factor, SF2, as recommended by reference 3. A scatter factor of 4 is used when there is no full-scale fatigue test data and no load substantiation through a flight and ground loads survey. A factor of 3 is used when there is either fatigue test data but no load survey or a load survey but no fatigue test data. A factor of 2 is used when there is fatigue test data and a load survey.

Given the above three quantities, the repeat inspection interval is found according to the following formula

$$\text{Repeat Inspection Interval} = (T_{crit} - T_{det}) / SF2$$

For other critical areas the repeat inspection intervals were determined based on fatigue test results or were adopted from existing inspection documents, such as the Airframe Airworthiness Limitations Manual.

The recommended repeat inspection intervals for each PSE are presented in the SA226 and SA227 SID [16]. Figure 10 summarizes how the inspection intervals were obtained based on crack growth analysis. Scatter factors of 2 are assumed.

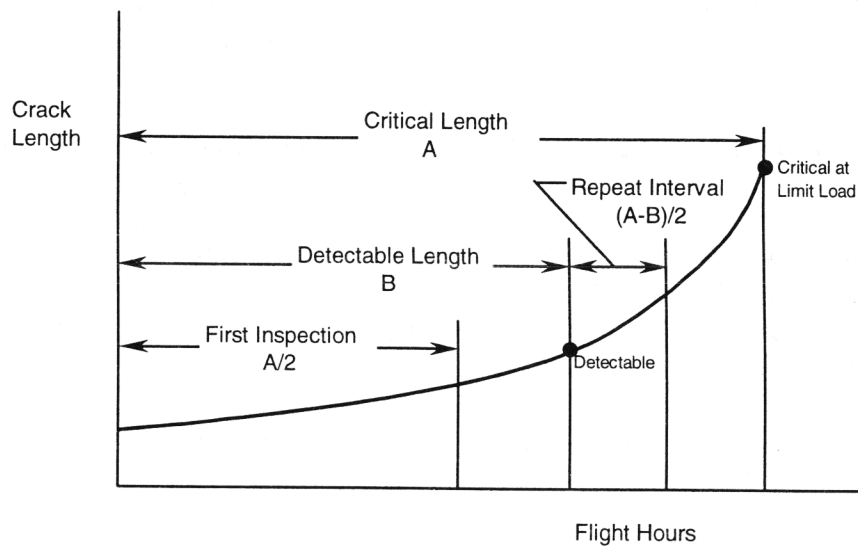

FIGURE 10. INSPECTION INTERVAL AND CRACK GROWTH CURVE RELATIONSHIP

3.7 DETERMINE THE ONSET OF WIDESPREAD FATIGUE DAMAGE.

Widespread Fatigue Damage (WFD) in a structure is characterized by the presence of cracks at several, adjacent structural details or structural elements. When such cracks grow in size and density, there comes a point at which the structure can no longer meet its damage tolerance requirement. WFD can occur as Multiple-Site Damage (MSD) or as Multiple-Element Damage (MED).

MSD is characterized by the simultaneous presence of fatigue cracks in the same structural element. Simultaneous cracking at multiple locations occurs when a particular structural feature is replicated many times and exposed to a near-uniform stress at all locations. Examples of such structure in the SA226 and SA227 are the T-stringer and skin at the crown and belly of the fuselage and the cargo door hinge.

MED is characterized by the simultaneous presence of fatigue cracks in similar adjacent structural elements in a multiload path component. Chordwise wing skin splices in the SA226 and SA227 are examples of such structure.

Initially, such cracks may be nonuniform in size and grow independently of one another. They begin to interact with their neighbors as they grow. Interaction can result in a significant increase in crack propagation rate and/or a reduction in residual strength capability. Due to their relatively small sizes, they are difficult to detect, and thus pose the risk of sudden coalescent and total structural failure without warning. Damage due to external sources – a failed propeller blade, for instance – superposed on WFD can also be catastrophic.

One assumption made regarding WFD in this report is that the analysis may consider only average quality flaws in the adjacent structural elements. Although a rogue flaw must be

assumed when considering the time to critical crack size in a PSE, the probability of rogue flaws occurring at multiple sites or elements in adjacent structure is extremely remote and may be neglected.

On the preceding basis the SA226 full-scale fatigue test provides valuable information about the susceptibility of the SA226 and SA227 aircraft to WFD during the operation life goal of 50,000 hours. Near the conclusion of the 105,000 hour test, a 5-inch longitudinal saw cut was made in the skin and T-stringer at the crown of the fuselage. The application of the 7-psi differential pressure did not cause unstable growth of this cut. In addition, no other areas of the pressure vessel failed catastrophically before completion of the test. Cracks that did grow were clearly visible and were either repaired or monitored further.

Saw cuts were also made in the main wing spar just before completion of the test. Application of limit load caused no catastrophic failures in any of the spar elements or chordwise skin splices.

In addition, it is important to note that the operator survey conducted in Phase I showed that for all three flight profiles (commuter, cargo, and executive) the stress spectrum is less severe than that used for the full-scale fatigue test.

Therefore, the time to onset of WFD for the wing, fuselage, and tail structure is determined to be greater than 105,000 hours with a high degree of certainty and greater than 50,000 hours (the goal of this program) with a very high degree of certainty.

4. PHASE III TASKS.

Phase III of development of the supplemental inspection document consisted of three tasks:

- a. Develop and analyze recommended design changes for the SA226 and SA227
- b. Develop and publish the Supplemental Inspection Document for the SA226 and SA227.
- c. Prepare the final report (this report) for the SID program

The Supplemental Inspection Document for the Fairchild SA226 and SA227 was also developed and published during Phase III. The SID was developed by taking all inspections related to primary structure from the existing Airframe Airworthiness Limitations Manual. Where necessary, the inspections were augmented or modified to reflect new inspection intervals determined in Phase II or to incorporate improved NDI procedures. Inspections that were not previously required have been added to the SID. The SID also incorporates the recommended structural modifications.

Finally, this report was prepared to summarize all work performed during the SID development program.

5. CONCLUSIONS AND RECOMMENDATIONS.

The SID document should be implemented to allow operators who so choose to continue safe operation of the aircraft to 50,000 flight hours.

6. REFERENCES.

1. "Metro III Wing Structural Analysis," Fairchild Report R653, 1980.
2. "Wing Static Test Report," Fairchild Report STTP 1128, 1990.
3. "Development of a Supplemental Inspection Document for SA226 and SA227 Aircraft Interim Report I," Final Report DOT/FAA/AR-99/20 P1, May 1997.
4. "Development of a Supplemental Inspection Document for SA226 and SA227 Aircraft Interim Report II," Final Report DOT/FAA/AR-99/20 P2, October 1998.
5. "SA226 Full-Scale Fatigue Test Results," Fairchild Report 2601 R781, October 1980.
6. "Fatigue Evaluation of Wing and Associated Structure on Small Aircraft," AFS0120-73-2, May 1973.
7. "General Aviation Aircraft-Normal Acceleration Data Analysis and Collection Project," Final Report DOT/FAA/CT-91/20, February 1993.
8. R. D. Christian, "FAR 23 Fatigue Substantiation Procedures: GAMA Committee Report," Society of Automotive Engineers Paper No. 710403, , 1971.
9. Engineering Sciences Data Unit ESDU 69023, "Average Gust Frequencies, Subsonic Transport Aircraft," The Royal Aeronautical Society.
10. "Development of a Supplemental Inspection Document for SA226 and SA227 Aircraft Interim Report II," Appendix F, Final Report DOT/FAA/AR-99/20 P2, October 1998.
11. "General Specification for Aircraft Structures," United States Air Force AFGS-87221A, June 8, 1990.
12. "Damage Tolerance Assessment Handbook Volume II: Airframe Damage Tolerance Evaluation," Final Report DOT/FAA/CT-93/69 II, October 1993.
13. "Supplemental Inspection Document, Model 402 Piston Aircraft," Cessna Report, April 1998.
14. "Supplemental Inspection Document Development Program for the Cessna Model 402," Final Report DOT/FAA/AR-98/66, March 1999.
15. "Fatigue Crack growth Computer Program "NASGRO" Version 3.00 Reference Manual," NASA Document JSC-22267B, November 1998.
16. "Supplemental Inspection Document, Fairchild SA226&SA227 Series Turboprop Aircraft," August 1999.

SUPPLEMENTAL INSPECTION DOCUMENT

**FAIRCHILD SA226 & SA227
SERIES TURBOPROP
AIRCRAFT**

FAIRCHILD AEROSPACE
SA226 & SA227 SERIES
SUPPLEMENTAL INSPECTION DOCUMENT

LIST OF EFFECTIVE PAGES

SUBJECT

PAGE

DATE

FAIRCHILD AEROSPACE
SA226 & SA227 SERIES
SUPPLEMENTAL INSPECTION DOCUMENT

RECORD OF REVISIONS

NO.	ISSUE DATE	DATE FILED	FILED BY	NO.	ISSUE DATE	DATE FILED	FILED BY

FAIRCHILD AEROSPACE
SA226 & SA227 SERIES
SUPPLEMENTAL INSPECTION DOCUMENT

TABLE OF CONTENTS

LIST OF EFFECTIVE PAGES.....	II
RECORD OF REVISIONS.....	III
TABLE OF CONTENTS	IV
APPLICABILITY.....	V
INTRODUCTION	VI
SECTION I – TECHNICAL DOCUMENT REFERENCE.....	1
MAINTENANCE/REPAIR MANUALS	1
SERVICE BULLETINS	1
FIELD MAINTENANCE PROCEDURES	1
SECTION II – LIST OF SUPPLEMENTAL INSPECTION DOCUMENTS.....	1
SUMMARY OF INSPECTIONS BY FLIGHT HOURS - SA226.....	2
SUMMARY OF INSPECTIONS BY FLIGHT HOURS - SA227	3
SECTION III – SUPPLEMENTAL INSPECTION DOCUMENTS.....	1
SA226/SA227 CONTROL COLUMN ROLLER BEARING	1
SA226/SA227 CARGO DOOR HINGE.....	2
SA226/SA227 RIB STRAP AT HORIZONTAL STABILIZER REAR SPAR AT BL 3.1	3
SA226 WING MAIN SPAR LOWER CAP AT STATION 99	4
SA226 WING MAIN SPAR LOWER CAP AT STATION 9	5
SA226/SA227 WING MAIN SPAR LOWER CAP AT STATION 9	6
SA226 WING REAR SPAR LOWER CAP AT STATION 27	7
SA227 WING MAIN SPAR LOWER CAP AT STATION 99	8
SA226/SA227 LOWER WING SKIN SPLICE AT WS 27	9
SA226/SA227 WING LOWER CENTER SECTION SKIN AT LANDING LIGHT CUTOUT	10
SA227 ENGINE MOUNT AT FIREWALL	11
SECTION IV – INSPECTION METHODS AND REQUIREMENTS.....	1
GENERAL REQUIREMENTS	1
GENERAL EDDY-CURRENT INSPECTION.....	2
GENERAL FLUORESCENT LIQUID PENETRANT INSPECTION.....	3
GENERAL MAGNETIC PARTICLE INSPECTION.....	4
GENERAL RADIOGRAPHY INSPECTION.....	5
SA226/SA227 CARGO DOOR HINGE.....	6
SA226 WING MAIN SPAR LOWER CAP AT STATION 99	8
SA226 WING MAIN SPAR LOWER CAP AT STATION 9	10
SA226 WING REAR SPAR LOWER CAP AT STATION 27	11
SA227 WING MAIN SPAR LOWER CAP AT STATION 99	13
SA226 MAIN SPAR AT WS 9.0	14
SA226/SA227 LOWER WING SKIN SPLICE AT WS 27	15
SA226/SA227 WING LOWER CENTER SECTION SKIN AT LANDING LIGHT CUTOUT	18
SA227 ENGINE MOUNT AT FIREWALL	20

FAIRCHILD AEROSPACE
SA226 & SA227 SERIES
SUPPLEMENTAL INSPECTION DOCUMENT

APPLICABILITY

MODEL	YEAR CERTIFIED	SERIAL NOS.
SA226-T	1970	201-248
SA226-T(A)	1974	249-291
SA226-T(B)	1978	276, 292-417
SA226-AT	1970	001-074
SA226-TC	1970	201-396, 398-413, 418, 419
SA227-TT	1981	421-541
SA227-TT(300)	1984	447, 465, 471, 483, 512, 518, 521, 527, 529, 536
SA227-AT	1981	421B, 423-631, 695
SA227-AC	1981	406, 415, 416, 420-788
SA227-BC	1989	762, 764, 766, 770-789
SA227-CC	1990	784, 790-826, 828, 830-839, 845-880, 882-904

**THE SA226/SA226 SERIES SUPPLEMENTAL INSPECTION DOCUMENT IS VALID FOR SA226 AND
SA227 AIRCRAFT WITH LESS THAN 50,000 FLIGHT HOURS.**

FAIRCHILD AEROSPACE
SA226 & SA227 SERIES
SUPPLEMENTAL INSPECTION DOCUMENT

INTRODUCTION

1.0 DISCUSSION

1.1 Introduction

The Supplemental Structural Inspection Program for Fairchild SA226/SA227 aircraft is based on current aircraft usage, material and airframe tests, and damage tolerance analysis. A practical inspection program has been established for each Principal Structural Element (PSE), where

a PSE is a structural element whose failure, if it remains undetected, could lead to loss of the aircraft. Selection of a PSE is influenced by the susceptibility of a structural area, part, or element to fatigue, corrosion, stress corrosion, or accidental damage.

The inspection program consists of supplemental inspections as required for continued airworthiness of the aircraft as they age. The existing inspection program is considered adequate for detecting corrosion and accidental damage. The emphasis of the Supplemental Structural Inspection Program is to detect fatigue damage whose probability increases with time.

The Supplemental Structural Inspection Program was sponsored by the FAA and developed through the combined efforts of Fairchild, and the Metro/Merlin/Expediter operators. This program is valid for SA226 and SA227 aircraft with less than 50,000 flight hours.

1.2 History

The Fairchild SA226/SA227 series aircraft (the "Metro", "Merlin", and "Expediter") were produced from 1970 to 1999. During those 30 years, approximately 900 aircraft entered service and the design underwent extensive development to increase its economic usefulness. The maximum takeoff weight grew from 12,500 lbs to 16,500 lbs. Many aircraft in the fleet have exceeded 30,000 flight hours of operation. The original design goal for the aircraft was an economic life of 35,000 hours. It is expected that the present program will support continued safe operation to 50,000 hours.

The SA226 and SA227 are twin turboprop aircraft that can be configured for cargo, executive, or 19-seat commuter operation. Structurally there is little difference between the SA226 and SA227. The primary difference is that the SA227 wing span is longer by 10 feet and strengthened to support higher takeoff weights. Both models have a constant circular cross-section fuselage, which is 33 inches in radius and can be pressurized to 7 psi.

1.3 Objective

The objective of the Supplemental Structural Inspection Program is the detection of damage due to fatigue, overload, or corrosion through the practical use of Nondestructive Inspection (NDI) methods. The Supplemental Inspection Document (SID) addresses primary and secondary airframe components only. Powerplant, electrical items, and primary and secondary systems are not addressed by this document.

To establish the basis for those items included, the following assumptions have been made.

- A. The aircraft has been maintained in accordance with Fairchild recommendations or equivalent.
- B. Where the SID is directed to a specific part or component, it is implied that the inspection will include observation and evaluation of the surrounding area of parts and equipment. Any discrepancies found during this inspection outside the scope of the SID should be reported to Fairchild through the existing condition reporting system so that changes can be made to the SID where necessary.

FAIRCHILD AEROSPACE
SA226 & SA227 SERIES
SUPPLEMENTAL INSPECTION DOCUMENT

- C. Aircraft modified by Supplemental Type Certificate (STC) are not the responsibility of Fairchild. Any inspections called for in Fairchild manuals or the SID that have areas that have been modified by STC shall automatically be referred to the STC holder by the owner and/or maintenance organization for obtaining FAA approval guidelines.

2.0 PRINCIPAL STRUCTURAL ELEMENTS

2.1 Rationale Used to Select Principal Structural Elements

An aircraft component is classified as a Principal Structural Element (PSE) if the component contributes significantly to carrying flight and ground loads and if failure of the component could result in catastrophic failure of the airframe.

2.2 Selection Criteria

The factors used to determine the PSEs in this document include the following.

A. SERVICE EXPERIENCE

A review of Service Bulletins and FAA Service Difficulty Reports compiled over the history of the airplane has pointed to known structural problem areas. Where component life is unacceptably short without modification of the structure, service bulletins have been required.

B. STRESS ANALYSIS

Extensive finite element modeling of the wing and certain other components was carried out in support of certification. The accuracy of the models has been checked by full-scale static testing, providing confidence in the use of results for locations other than strain gage locations.

C. STRAIN SURVEYS

Several strain surveys – both in flight and on the ground – have provided stress data at important locations throughout the airframe. Much of this data was correlated to analytical results from finite element models.

D. FATIGUE TESTING

A complete SA226 airframe was fatigue tested in 1980 under realistic flight and pressurization loads. Cracks that developed were monitored for growth throughout the duration of the test. Many of the problem areas have since been updated with more fatigue-resistant designs via service bulletins and production design changes. At the conclusion of the test, several fail-safe cuts were inflicted on the structure and limit load was applied to all the major components. In addition loads up to 91% of ultimate were applied to the wing structure.

3.0 DURABILITY – FATIGUE AND DAMAGE TOLERANCE

3.1 Aircraft Usage

Aircraft usage data for the SID program was based on a sampling of the in-service utilization of the aircraft. These data were used in combination with load exceedance tables to develop representative fatigue loads spectra. Operational data for development of the Supplemental Inspection Program was obtained from a survey covering a total of 70 aircraft and 871 flights during 1996-97. The breakdown of the flights is as follows:

FAIRCHILD AEROSPACE
SA226 & SA227 SERIES
SUPPLEMENTAL INSPECTION DOCUMENT

- Two commuter operators: 535 flights with 32 aircraft
- One cargo operator: 248 flights with 31 aircraft
- One executive operator: 190 flights with 7 aircraft

Additional information was gathered from the Official Airline Guide and teleconferences with operators. A graphical summary of the usage data from the survey is shown in Figure 1.

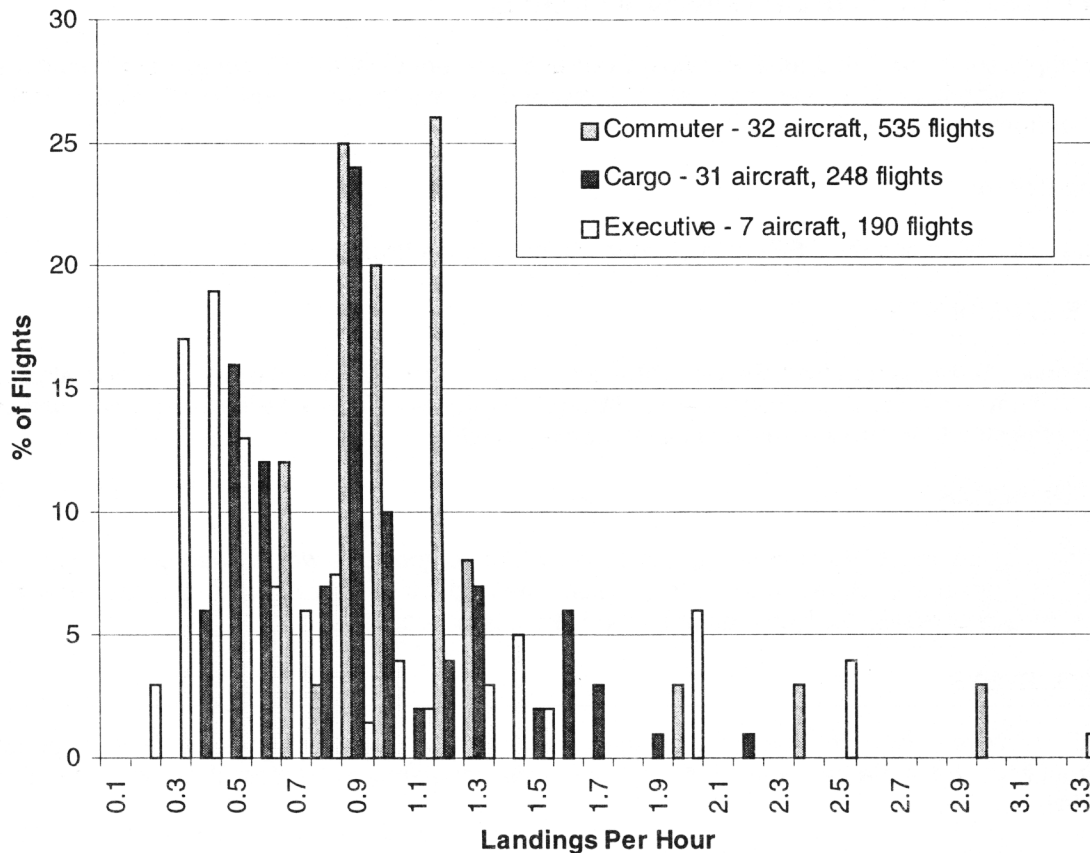

Figure 1. Flight Length Summary (Sheet 1)

3.2 Stress Spectrum

A fatigue loads spectrum, in terms of gross area stress and based on the usage flight profiles, was developed for each PSE to be analyzed. The spectrum represents all significant loads, including those arising from taxi, thrust, flight (gust and maneuver), and landing impact. The resulting spectrum is a representative flight-by-flight, cycle-by-cycle random loading sequence that reflects the appropriate and significant airplane response characteristics.

After reviewing the aircraft usage data and the way in which the surveyed aircraft were flown, four sets of stress spectra were developed – one for the SA226, and one for each of the three SA227 flight profiles – as described in Section 3.3.

FAIRCHILD AEROSPACE
SA226 & SA227 SERIES
SUPPLEMENTAL INSPECTION DOCUMENT

3.3 Description of Flight Spectrum

The SA226 flight profile consists of one 30-minute flight. After takeoff at 11,800 lbs, the aircraft climbs to altitude at 160 knots. Cruise is at 20,000 feet and 250 knots, after which the aircraft descends at 220 knots and lands weighing 11,000 lbs. This profile represents the severest commuter operation for the SA226, flown early in their lifetimes. Many of these planes were later converted to cargo configuration with lower utilization rates and less severe flight profiles.

There are three SA227 profiles: Commuter (one 30-minute flight), Cargo (one 60-minute flight), and Executive (one 120-minute flight). Each flight has a climb speed of 160 knots, cruise speed of 250 knots, and descent speed of 220 knots. However, the cargo flight naturally has the highest takeoff and landing weights whereas the longer executive flight reaches highest altitudes.

The stress spectrum used for PSEs present on only the SA227 was based on a composite SA227 flight profile. The composite profile consists of one commuter flight, three cargo flights, and one executive flight. This yields a total of five flights spanning 5.5 hours. The stress spectrum used for PSEs present on both the SA226 and SA227 aircraft was based on the more severe SA226 commuter profile.

3.4 Damage Tolerance and Fatigue Assessments

The damage tolerance and fatigue assessments provide the basis for establishing inspection frequency requirements for each PSE. The evaluation includes a determination of the probable location and modes of damage and has been based on analytical results, available test data, and service experience. The evaluation includes application of appropriate scatter factors to fatigue test data as well as the determination of crack growth rates and residual strength. Linear elastic fracture mechanics has been used to perform the majority of the damage tolerance analysis.

In the evaluation, particular attention is paid to potential structural problem areas associated with aging aircraft. Examples include (a) large areas of structure working at the same stress level, which could cause widespread fatigue damage; (b) a number of small, undetectable, and adjacent cracks capable of suddenly joining into a long crack (e.g., a line of rivet holes); (c) redistribution of load from adjacent failing or failed parts causing accelerated damage to alternate load paths (i.e., the "domino effect"); and (d) concurrent failure of multiple load path structure (e.g., crack arrest structure).

Initial inspections were based on the shorter of analytical crack growth curves, fatigue test results, or service experience. Where analytical crack growth was used, the initial inspection was set at $c_{crit}/2$, where c_{crit} is the crack size at which the structure can no longer support limit load. The initial crack size was assumed to be 0.05 inch in most cases. Figure 2 shows a typical crack growth curve and the inspection intervals determined therefrom.

FAIRCHILD AEROSPACE
SA226 & SA227 SERIES
SUPPLEMENTAL INSPECTION DOCUMENT

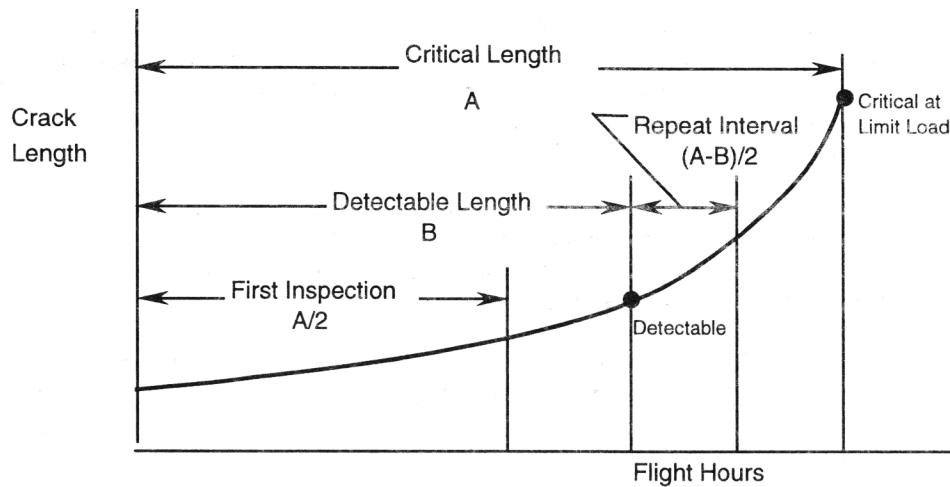

Figure 2. Typical Crack Growth Curve

4.0 REPORTING – COMMUNICATIONS

For the SID program to be successful at assuring continued airworthiness in the most economical manner, it is essential that a free flow of information exist between the operators, the FAA, and Fairchild. Significant details of inspection results, repairs, and modifications accomplished must be communicated to Fairchild in order to assess the effectiveness of the recommended inspection procedures and inspection intervals.

Additionally, items not previously considered for inclusion in the SID may be uncovered through operator inspections and reporting. These items will be evaluated by Fairchild and, if applicable to the aircraft configurations concerned, will be added to the SID for the benefit of all operators.

The reporting methods described in the following pages have been established within the Field Support department of Fairchild to aid in this process. Further information can be obtained by contacting Fairchild Field Support Engineering.

4.1 Discrepancy Reporting

Discrepancy reporting is essential to provide for adjustment of the inspection thresholds and repeat intervals as well as adding or deleting inspections. It may be possible to improve the inspection methods, repairs, and modifications involving PSEs based on the data reported.

All cracks, sheared fasteners, and significant corrosion found during inspections should be reported to Fairchild within 10 days. The PSE inspection results are to be recorded and reported on a form as shown on the following pages.

FAIRCHILD AEROSPACE
SA226 & SA227 SERIES
SUPPLEMENTAL INSPECTION DOCUMENT

4.2 Discrepancy Form Disposition

Send all available data including forms, repair data, photographs, sketches, etc., to:

Fairchild Aerospace
Service Engineering
Dept 551
P.O. Box 790490
San Antonio, TX 78279
FAX (210) 820-8602

NOTE: This system does not supersede the normal channels of communication for items not covered by the SID

4.3 Fairchild Follow-up Action

All SID reports will be reviewed by Fairchild Engineering to determine if any of the following actions should be taken:

- Check the effect on structural or operational integrity
- Check other high-time aircraft to determine whether a service bulletin should be issued
- Determine whether reinforcement is required
- Revise the SID if required

5.0 INSPECTION METHODS

A very important part of the SID program is selecting and evaluating state-of-the-art nondestructive inspection (NDI) methods applicable to each PSE and determining a minimum detectable cracks length, c_{det} , for each NDI method. The minimum detectable crack length is used in conjunction with the critical crack length, c_{crit} , to define the life interval for the crack to grow from c_{det} to c_{crit} . This interval, $(c_{crit}-c_{det})/2$, is used to define the repeat inspection frequency for the SID program's required inspections. The threshold inspection generally occurs at $c_{crit}/2$. For a given NDI method and PSE, c_{det} corresponds to a crack size with 90% probability of detection. An example of repeat and initial inspection interval determination is shown in Figure 2.

Potential NDI methods were selected and evaluated on the basis of crack orientation, location, c_{crit} , part thickness, and accessibility. Inspection reliability depends on the size of the inspection task, human factors (such as qualifications and alertness of inspector), equipment reliability, and physical access. Visual, radiographic, liquid penetrant, eddy-current, and magnetic particle methods were considered. A description of each of these methods is presented in Section IV – Inspection Methods and Requirements. Additional information on NDI methods can be found in the Structural Repair Manual for your aircraft.

6.0 RELATED DOCUMENTS

6.1 Existing Inspections, Modifications, and Repair Documents

Fairchild has published a number of documents that are useful to maintaining the airworthiness of aircraft:

- SA226, SA227 & 227CC Maintenance Manuals
- SA226 & SA227 Component Maintenance Manuals
- SA226 & SA227 Illustrated Parts Catalogs
- SA226 & SA227 Service Information (Service Bulletins, Service Letters, and Service Notes)
- SA226 & SA227 Structural Repair Manuals

FAIRCHILD AEROSPACE
SA226 & SA227 SERIES
SUPPLEMENTAL INSPECTION DOCUMENT

- SA226 & SA227 Airframe Airworthiness Limitations Manuals

For information or to obtain these documents, contact:

Fairchild Aerospace
Technical Publications
P.O. Box 790490
San Antonio, TX 78279
FAX (210) 820-8609

6.2 Service Letters/Bulletins Affected by SID

As an aid to operators, a listing of Service Bulletins pertaining to the SID is given in Section I – Technical Document Reference. For information concerning the technical data included in these Service Bulletins that apply to your aircraft, contact Fairchild Customer Support at (210) 820 7607. A comprehensive list of all technical publications, including service letters and bulletins, applicable to each airplane model is also available. This information can be obtained by contacting Spares Department at (800) 577-7273.

7.0 APPLICABILITY/LIMITATIONS

This SID manual is applicable to all SA226 and SA227 aircraft with less than 50,000 flight hours. Serial numbers originally certified include those listed previously in the Applicability section of this manual.

8.0 PSE DETAILS

This section contains the significant details selected by the rationale process described in paragraph 2.0. These items are considered significant to maintain continued airworthiness of the Fairchild SA226 and SA227 series aircraft. Service Bulletins pertaining to the PSEs are listed in Section I – Technical Document Reference.

A summary of the PSEs is presented in Section II – List of Supplemental Inspection Documents. This can be used as a checklist by operators. A summary of inspections by flight hours or flight cycles is also given.

8.1 PSE Data Sheets

A data sheet for each PSE is provided in Section III – Supplemental Inspection Documents. Each data sheet contains the following information:

- Supplemental Inspection Number
- Title
- Effectivity
- Inspection Compliance
- Initial Inspection Interval
- Repeat Inspection Interval
- Purpose
- Inspection Instructions
- Access/Location
- Detectable Crack Size
- Inspection Procedure
- Repair/Modification
- Comments

FAIRCHILD AEROSPACE
SA226 & SA227 SERIES
SUPPLEMENTAL INSPECTION DOCUMENT

NOTE 1: Listing of a Detectable Crack Size does not imply that cracks are allowed. No unrepaired cracks are allowed. Damaged parts must be repaired or replaced.

NOTE 2: Accomplishment of the SID inspections does not in any way replace preflight inspections, good maintenance practices, or maintenance and inspections specified in other documents.

8.2 Repair Information/Modifications

Modifications and repairs may be made in accordance with approved Fairchild manuals, service bulletins, or other approved documents. Repairs not covered by an existing approved document may be coordinated with the assistance of Fairchild Service Engineering at FAX (210) 820-8602.

FAIRCHILD AEROSPACE
SA226 & SA227 SERIES
SUPPLEMENTAL INSPECTION DOCUMENT

DISCREPANCY REPORT

SID NO: AIRPLANE LOCATION: S/N OF AIRPLANE:

INSPECTION CONDUCTED: Date: Airplane Total Hours: Cycles:
Component Total Hours: Cycles:

SERVICE HISTORY:

INSPECTION METHOD/LIMITS:

ACCESS REQUIRED:

REPAIR DESCRIPTION:

COMMENTS:

Enclose all available data including photos, sketches, etc., to:

Fairchild Aerospace
Service Engineering
P.O. Box 790490
San Antonio, TX 78279
FAX (210) 820-8602

FAIRCHILD AEROSPACE
SA226 & SA227 SERIES
 SUPPLEMENTAL INSPECTION DOCUMENT

SECTION I – TECHNICAL DOCUMENT REFERENCE

MAINTENANCE/REPAIR MANUALS

Aircraft	Number	Title
SA226	27-10054-047	Maintenance Manual
SA227	27-10054-095	Maintenance Manual
SA227 Commuter Category	27-10054-133	Maintenance Manual
SA226/SA227	27-10054-079	Structural Repair Manual
SA227 Commuter Category	27-10054-127	Structural Repair Manual

To obtain a Maintenance/Repair Manual, contact:

Fairchild Aerospace
 Spares Department
 P.O. Box 790490
 San Antonio, TX 78279
 (800) 577-7273

SERVICE BULLETINS

No.	Number	Title	Date	Reference SID
	226-27-061	Control Column Pivot Improvement	06-16-97	27-31-01
	227-27-042	Control Column Pivot Improvement	06-16-97	27-31-01
	226-55-011	Horizontal Stabilizer Beef-up	06-00-99	55-10-01
	227-55-007	Horizontal Stabilizer Beef-up	06-00-99	55-10-01
	227-71-008	Inspection/Modification of Upper Truss	02-07-97	71-21-01
	CC7-71-001	Inspection/Modification of Upper Truss	02-07-97	71-21-01

FIELD MAINTENANCE PROCEDURES

FMP-57-011	Eddy-Current Inspection Proc., BL 9	06-09-96	57-10-03
------------	-------------------------------------	----------	----------

Section III assumes that the following Service Bulletins have been accomplished. The intent of each of these Service Bulletins was required by FAA Airworthiness Directive.

226-53-007	Cargo Door Belt Frames
227-53-003	Cargo Door Belt Frames
226-55-010	Horizontal Stabilizer
227-55-006	Horizontal Stabilizer
226-32-065	MLG/NLG Yoke
227-32-039	MLG/NLG Yoke
CC7-32-007	MLG/NLG Yoke

To obtain a Service Bulletin listed above, contact:

Fairchild Aerospace
 Service Engineering
 P.O. Box 790490
 San Antonio, TX 78279
 FAX (210) 820-8602

FAIRCHILD AEROSPACE
SA226 & SA227 SERIES
 SUPPLEMENTAL INSPECTION DOCUMENT

SECTION II – LIST OF SUPPLEMENTAL INSPECTION DOCUMENTS

SID No.	Title	Date	Effectivity	Initial	Repeat
27-31-01	SA226/SA227 Control Column Roller Bearing	Aug 31/99	SA226– All SA227 – 784, 790-891, 894	1,000 Hrs	N/A
52-31-01	SA226/SA227 Cargo Door Hinge	Aug 31/99	SA226 – All SA227 – All	37,500 Cycles	1,000 Cycles
55-10-01	SA226/SA227 Rib Strap at Horizontal Stabilizer Rear Spar at BL 3.1	Aug 31/99	SA226 – All SA227 – Up to S/N 786	35,000 Hrs	N/A
57-10-01	SA226 Wing Main Spar Lower Cap at Station 99	Aug 31/99	SA226 – All	24,750 Hrs	2,750 Hrs
57-10-02	SA226 Wing Main Spar Lower Cap at Station 9	Aug 31/99	Note 1	14,300 Hrs	10,000 Hrs
57-10-03	SA226 Wing Main Spar Lower Cap at Station 9	Aug 31/99	Note 1	14,300 Hrs	10,000 Hrs
57-10-04	SA226 Wing Rear Spar Lower Cap at Station 27	Aug 31/99	SA226 – All	16,500 Hrs	2,000 Hrs
57-10-05	SA227 Wing Main Spar Lower Cap at Station 99	Aug 31/99	SA227 – All	20,000 Hrs	5,000 Hrs
57-10-06	SA226/SA227 Lower Wing Skin Splice at Station 27	Aug 31/99	SA226 – All SA227 – Up to S/N 591	11,800 Hrs	5,500 Hrs
57-10-07	SA226/SA227 Wing Lower Center Section Skin at Landing Light Cutout	Aug 31/99	SA226 – All SA227 – TT - All	11,000 Hrs	2,500 Hrs
71-21-01	SA227 Engine Mount at Firewall	Aug 31/99	Note 1	1,000 Hrs	N/A

NOTE 1: Refer to the inspection document in section III for effectivity.

FAIRCHILD AEROSPACE
SA226 & SA227 SERIES
 SUPPLEMENTAL INSPECTION DOCUMENT

SUMMARY OF INSPECTIONS BY FLIGHT HOURS - SA226

Initial Inspections

INITIAL INSPECTION	EFFECTIVITY	SID NUMBERS
1,000 Hrs	All	27-31-01
11,000 Hrs	All	57-10-01
11,800 Hrs	All	57-10-06
14,300 Hrs	All	57-10-02, 57-10-03
16,500 Hrs	All	57-10-04
24,750 Hrs	All	57-10-01
30,000 Hrs	All	55-10-01
37,500 Cycles	All	52-31-01

Repeat Inspection Intervals

REPEAT INSPECTION	EFFECTIVITY	SID NUMBERS
1,000 Cycles	All	52-31-01
2,000 Hrs	All	57-10-04
2,500 Hrs	All	57-10-07
2,750 Hrs	All	57-10-01
5,500 Hrs	All	57-10-06
10,000 Hrs	All	57-10-02, 57-10-03

FAIRCHILD AEROSPACE
SA226 & SA227 SERIES
 SUPPLEMENTAL INSPECTION DOCUMENT

SUMMARY OF INSPECTIONS BY FLIGHT HOURS - SA227

Initial Inspections

INITIAL INSPECTION	EFFECTIVITY	SID NUMBERS
1,000 Hrs	784, 790-891, 894	27-31-01
1,000 Hrs	All with 27-62114 engine mount truss except S/N 892, 893, and 895 and up	71-21-01
11,000 Hrs	All TT	57-10-07
11,800 Hrs	All up to S/N 591	57-10-06
20,000 Hrs	All	57-10-05
35,000 Hrs	All up to S/N 786	55-10-01
37,500 Cycles	All	52-31-01

Repeat Inspection Intervals

REPEAT INSPECTION	EFFECTIVITY	SID NUMBERS
1,000 Cycles	All	52-31-01
2,500 Hrs	All TT	57-10-07
5,000 Hrs	All	57-10-05
5,500 Hrs	All up to S/N 591	57-10-06

FAIRCHILD AEROSPACE
SA226 & SA227 SERIES
SUPPLEMENTAL INSPECTION DOCUMENT

SECTION III – SUPPLEMENTAL INSPECTION DOCUMENTS

TITLE **SUPPLEMENTAL INSPECTION NUMBER: 27-31-01**

SA226/SA227 Control Column Roller Bearing

EFFECTIVITY

SA226 - All
SA227 – 784, 790-891, 894

INSPECTION COMPLIANCE

INITIAL	1,000 HOURS
REPEAT	N/A

PURPOSE

Replacement of control column roller bearing and support structure with fatigue-resistant design.

INSPECTION INSTRUCTIONS

1. Accomplish Fairchild Service Bulletin 226-27-061 or 227-27-042 if not already accomplished.

ACCESS/LOCATION

Cockpit Floor

DETECTABLE CRACK SIZE

N/A

INSPECTION METHOD

N/A

REPAIR/MODIFICATION

Refer to Fairchild Service Bulletin 226-27-061 or 227-27-042.

COMMENTS

FAIRCHILD AEROSPACE
SA226 & SA227 SERIES
SUPPLEMENTAL INSPECTION DOCUMENT

TITLE

SA226/SA227 Cargo Door Hinge

SUPPLEMENTAL INSPECTION NUMBER: 52-31-01

EFFECTIVITY

SA226 - All

SA227 - All

INSPECTION COMPLIANCE

INITIAL 37,500 CYCLES or 25,000 HOURS
SINCE NEW

REPEAT 1,000 CYCLES or 650 HOURS
(if not replaced)

PURPOSE

Inspection or replacement of cargo door hinge.

INSPECTION INSTRUCTIONS

1. Hinge may be replaced at 37,500 cycles or any time thereafter in lieu of inspection. See the parts catalog and maintenance manual for replacement information.
2. If inspection is chosen, refer to Section IV (NDI Inspection), Supplemental Inspection Number 52-31-01 for specific inspection instructions.

ACCESS/LOCATION

Fuselage at cargo door upper sill

DETECTABLE CRACK SIZE

0.10 inch

INSPECTION METHOD

Surface Eddy Current

REPAIR/MODIFICATION

Replace with a new part before further flight.

COMMENTS

If a crack is detected, contact Fairchild Service Engineering.

FAIRCHILD AEROSPACE
SA226 & SA227 SERIES
SUPPLEMENTAL INSPECTION DOCUMENT

TITLE

SUPPLEMENTAL INSPECTION NUMBER: 55-10-01

SA226/SA227 Rib Strap at Horizontal Stabilizer Rear Spar at BL 3.1

EFFECTIVITY

SA226 - All
SA227 - All airplanes up to S/N 786

INSPECTION COMPLIANCE

INITIAL 35,000 HOURS SINCE NEW
REPEAT N/A

PURPOSE

Reinforcement of horizontal stabilizer rear spar upper and lower caps to eliminate possible fatigue cracking of rib strap at BL 3.1.

INSPECTION INSTRUCTIONS

1. Accomplish Fairchild Service Bulletin 226-55-011 or 227-55-007 if not already accomplished.

ACCESS/LOCATION

Horizontal Stabilizer Rear Spar

DETECTABLE CRACK SIZE

N/A

INSPECTION METHOD

Refer to Fairchild Service Bulletin 226-55-011 or 227-55-007.

REPAIR/MODIFICATION

Refer to Fairchild Service Bulletin 226-55-011 or 227-55-007.

COMMENTS

FAIRCHILD AEROSPACE
SA226 & SA227 SERIES
SUPPLEMENTAL INSPECTION DOCUMENT

TITLE

SUPPLEMENTAL INSPECTION NUMBER: 57-10-01

SA226 Wing Main Spar Lower Cap at Station 99

EFFECTIVITY

SA226 - All

INSPECTION COMPLIANCE

INITIAL	24,750 HOURS
REPEAT	2,750 HOURS

PURPOSE

Inspection of aluminum spar cap extrusions for fatigue cracks or other damage.

INSPECTION INSTRUCTIONS

1. Defuel the wings in accordance with the applicable Service/Maintenance Manual (MM).
2. Gain access to the spar at station 99 by removing the outboard nacelle access panel beneath the main spar, the two fuel tank access panels outboard of the nacelle, and the fuel tank access panel aft of the nacelle. Refer to SA226 MM for removal instructions.
3. Inspect left and right wing. Refer to Section IV (NDI Inspection), Supplemental Inspection Number 57-10-01 for specific inspection instructions.
4. Vacuum all loose sealant and other particles from fuel tank.
5. Reseal in accordance with SRM 51-30-03
6. Close out the fuel tank and nacelle in accordance with the SA226 MM.

ACCESS/LOCATION

Wings

DETECTABLE CRACK SIZE

0.10 inch

INSPECTION METHOD

Surface Eddy Current

REPAIR/MODIFICATION

COMMENTS

Detection of a crack may indicate complete failure of the part. If a crack is detected, contact Fairchild Service Engineering.

FAIRCHILD AEROSPACE
SA226 & SA227 SERIES
SUPPLEMENTAL INSPECTION DOCUMENT

TITLE

SUPPLEMENTAL INSPECTION NUMBER: 57-10-02

SA226 Wing Main Spar Lower Cap at Station 9

EFFECTIVITY

SA226
T – 201-275, 277-291
T(B) – 276, 292-393 except 303E
TC – 201-397
AT – 001-074 except 070

INSPECTION COMPLIANCE

INITIAL 14,300 HOURS
REPEAT 10,000 HOURS

PURPOSE

Inspection of aluminum spar cap extrusions for fatigue cracks or other damage.

INSPECTION INSTRUCTIONS

1. If the forward and aft pressure plates do not have access panels installed at station 9, accomplish Fairchild Service Bulletin 226-57-006 (T) and (TB), 226-57-007 (AT), or 226-57-008 (TC).
2. Gain access to the main spar lower cap at station 9 by removing access panels on forward and aft pressure plates.
3. Inspect left and right wing. Refer to Section IV (NDI Inspection), Supplemental Inspection Number 57-10-02 for specific inspection instructions.
4. Reseal in accordance with SRM 51-30-03
5. Close out access panels in accordance with the Maintenance Manual.

ACCESS/LOCATION

Wings

DETECTABLE CRACK SIZE

0.10 inch

INSPECTION METHOD

Surface Eddy Current

REPAIR/MODIFICATION

COMMENTS

Detection of a crack may indicate complete failure of the part. If a crack is detected, contact Fairchild Service Engineering.

FAIRCHILD AEROSPACE
SA226 & SA227 SERIES
SUPPLEMENTAL INSPECTION DOCUMENT

TITLE

SUPPLEMENTAL INSPECTION NUMBER: 57-10-03

SA226/SA227 Wing Main Spar Lower Cap at Station 9

EFFECTIVITY

SA226
T(B) – 303E, 394-417
TC – 398-419
AT – 070
SA227 ALL

INSPECTION COMPLIANCE

INITIAL 14,300 HOURS
REPEAT 10,000 HOURS

PURPOSE

Inspection of aluminum spar cap extrusions for fatigue cracks or other damage.

INSPECTION INSTRUCTIONS

1. Inspect left and right wing per FMP 57-011. This document may be obtained from Fairchild Technical Publications. Inspect all bolt holes in the spar cap from wing station 7 to 11 left and right.

ACCESS/LOCATION

Wings

DETECTABLE CRACK SIZE

0.08 inch

INSPECTION METHOD

Bolt Hole Eddy Current

REPAIR/MODIFICATION

COMMENTS

If a crack is detected, contact Fairchild Service Engineering.

FAIRCHILD AEROSPACE
SA226 & SA227 SERIES
SUPPLEMENTAL INSPECTION DOCUMENT

TITLE

SUPPLEMENTAL INSPECTION NUMBER: 57-10-04

SA226 Wing Rear Spar Lower Cap at Station 27

EFFECTIVITY

SA226 - All

INSPECTION COMPLIANCE

INITIAL	16,500 HOURS
REPEAT	2,000 HOURS

PURPOSE

Inspection of aluminum spar cap angle for fatigue cracks or other damage.

INSPECTION INSTRUCTIONS

1. Remove wing fairing and access panel.
2. Inspect left and right wing. Refer to Section IV (NDI Inspection), Supplemental Inspection Number 57-10-04 for specific inspection instructions.
3. Close out access panel and install wing fairing.

ACCESS/LOCATION

Wings

DETECTABLE CRACK SIZE

0.10 inch

INSPECTION METHOD

Surface Eddy Current

REPAIR/MODIFICATION

COMMENTS

If a crack is detected, contact Fairchild Service Engineering.

FAIRCHILD AEROSPACE
SA226 & SA227 SERIES
SUPPLEMENTAL INSPECTION DOCUMENT

TITLE **SUPPLEMENTAL INSPECTION NUMBER: 57-10-05**

SA227 Wing Main Spar Lower Cap at Station 99

EFFECTIVITY

SA227 - All

INSPECTION COMPLIANCE

INITIAL	20,000 HOURS
REPEAT	5,000 HOURS

PURPOSE

Inspection of aluminum spar cap extrusions for fatigue cracks or other damage.

INSPECTION INSTRUCTIONS

1. Defuel the wings in accordance with the applicable Service/Maintenance Manual.
2. Gain access to the spar from stations 99 to 130 by removing the outboard nacelle access panel beneath the main spar, the fuel tank access panels outboard of the nacelle, and the fuel tank access panel aft of the nacelle. Refer to SA227 MM for removal instructions.
3. Inspect left and right wing. Refer to Section IV (NDI Inspection), Supplemental Inspection Number 57-10-05 for specific inspection instructions.
4. Vacuum all loose sealant and other particles from fuel tank.
5. Reseal in accordance with SA226/227/227CC SRM 51-30-03
6. Close out the fuel tank and nacelle in accordance with SA227227CC MM.

ACCESS/LOCATION

Wings

DETECTABLE CRACK SIZE

0.10 inch

INSPECTION METHOD

Surface Eddy Current

REPAIR/MODIFICATION

COMMENTS

Detection of a crack may indicate complete failure of the part. If a crack is detected, contact Fairchild Field Support Engineering.

FAIRCHILD AEROSPACE
SA226 & SA227 SERIES
SUPPLEMENTAL INSPECTION DOCUMENT

TITLE

SUPPLEMENTAL INSPECTION NUMBER: 57-10-06

SA226/SA227 Lower Wing Skin Splice at WS 27

EFFECTIVITY

INSPECTION COMPLIANCE

SA226 - All	INITIAL	11,800 HOURS
SA227 – Up to S/N 591	REPEAT	5,500 HOURS

PURPOSE

Inspect for cracks in belly skin at splice strap and in stringers 16-21 inboard of rib at WS 27.

INSPECTION INSTRUCTIONS

1. Gain access to inside of wing between main spar and rear spar by removing four access doors and two landing lights (models with landing lights on belly) or six access doors (models with no landing lights on belly). Refer to SA226/SA227 MM for removal instructions.
2. Inspect left and right wing. Refer to Section IV (NDI Inspection), Supplemental Inspection Number 57-10-06 for specific inspection instructions.
3. Close out the wing in accordance with SA226/SA227 MM.

ACCESS/LOCATION

DETECTABLE CRACK SIZE

Inside center wing

0.10 inch

INSPECTION METHOD

Surface Eddy Current

REPAIR/MODIFICATION

COMMENTS

If a crack is detected, contact Fairchild Service Engineering.

FAIRCHILD AEROSPACE
SA226 & SA227 SERIES
SUPPLEMENTAL INSPECTION DOCUMENT

TITLE **SUPPLEMENTAL INSPECTION NUMBER: 57-10-07**

SA226/SA227 Wing Lower Center Section Skin at Landing Light Cutout

EFFECTIVITY

SA226 - All
SA227-TT - All

INSPECTION COMPLIANCE

INITIAL	11,000 HOURS
REPEAT	2,500 HOURS

PURPOSE

Inspection of belly skin around landing light cutout for fatigue cracks and other damage.

INSPECTION INSTRUCTIONS

1. Refer to Section IV (NDI Inspection), Supplemental Inspection Number 57-10-07 for specific inspection instructions.

ACCESS/LOCATION

Wing

DETECTABLE CRACK SIZE

0.15 inch

INSPECTION METHOD

Surface Eddy Current

REPAIR/MODIFICATION

COMMENTS

If a crack is detected, contact Fairchild Service Engineering.

FAIRCHILD AEROSPACE
SA226 & SA227 SERIES
SUPPLEMENTAL INSPECTION DOCUMENT

TITLE

SUPPLEMENTAL INSPECTION NUMBER: 71-21-01

SA227 Engine Mount at Firewall

EFFECTIVITY

SA227 – All airplanes with
27-62114 engine mount truss
except S/N 892, 893, and 895 and up.

INSPECTION COMPLIANCE

INITIAL NEXT SCHEDULED ENGINE REMOVAL
OR WITHIN 1,000 HOURS
REPEAT N/A (ONE-TIME ONLY)

PURPOSE

Inspection of engine mount truss for cracks and replacement of washer.

INSPECTION INSTRUCTIONS

1. This SID inspection is not required if Fairchild Service Bulletin 227-71-008 or CC7-71-001 has already been accomplished on both engine mount trusses.
2. Remove the engine mount truss from the aircraft per the maintenance manual.
3. Refer to Section IV (NDI Inspection), Supplemental Inspection Number 71-21-01 for specific inspection instructions which are in addition to the Service Bulletin.
4. Accomplish Fairchild Service Bulletin 227-71-008 or CC7-71-001. The inspection portion of the bulletin is not required if this SID inspection is performed.

NOTE: PERFORMING MAINTENANCE ON BOTH ENGINES AT THE SAME TIME CAN INCREASE THE PROBABILITY OF DUAL ENGINE FAILURE. IT IS RECOMMENDED TO STAGGER ENGINE REMOVALS TO COMPLY WITH THIS SID.

ACCESS/LOCATION

Nacelle at Firewall

DETECTABLE CRACK SIZE

0.10 inch

INSPECTION METHOD

Fluorescent Penetrant

REPAIR/MODIFICATION

Refer to Fairchild Service Bulletin 227-71-008 or CC7-71-001.

COMMENTS

If a crack is detected, contact Fairchild Field Support Engineering.

FAIRCHILD AEROSPACE
SA226 & SA227 SERIES
SUPPLEMENTAL INSPECTION DOCUMENT

SECTION IV – INSPECTION METHODS AND REQUIREMENTS

GENERAL REQUIREMENTS

1. General

- A. Facilities performing nondestructive inspection as defined in this Supplemental Inspection Document must hold a valid FAA Repair Station Certificate with a Specialized Service Rating in the applicable method of nondestructive inspection.
- B. Facilities performing nondestructive inspection as defined in this SID must own or have access to test equipment capable of performing the inspection and reporting the test results as defined in this manual.
- C. Personnel performing nondestructive inspection defined in this Supplemental Inspection Document shall be certified to a minimum of Level II in the applicable inspection method as defined by the American Society for Nondestructive Testing, Recommended Practice Number SNT-TC-1A.
- D. Organizations and personnel engaged in the application of nondestructive inspection and operating under the jurisdiction of a foreign government shall use the appropriate documents issued by the applicable regulatory agency in complying with the above requirements.
- E. Further information on nondestructive testing can be found in the SA226/227/227CC Structural Repair Manual.

FAIRCHILD AEROSPACE
SA226 & SA227 SERIES
SUPPLEMENTAL INSPECTION DOCUMENT

GENERAL EDDY-CURRENT INSPECTION

1. General

- A. Eddy-current inspection is effective for the detection of surface or near surface cracks in nonferrous metals. The inspection is accomplished by inducing eddy currents into the part and observing electrical variations of the induced field. The character of the observed field change is displayed and interpreted to determine the nature of the indication. This method can be applied to airframe parts or assemblies where the inspection area is accessible to contact by the eddy-current probe. An important use of eddy-current inspection is for the detection of cracking caused by corrosion or stress in and around fastener holes. Bolt hole eddy-current probes are effective in detecting cracks emanating from the wall of a fastener hole. Surface probes can detect cracks around the fastener hole area with the fasteners installed.
- B. Eddy-current inspection equipment requires that good contact be made between the probe and the part being tested unless a specific procedure requires a certain amount of liftoff. The area to be tested must be clean, dry, and free of dirt, grease, loose paint, or any other contaminants which could interfere with the eddy-current inspection. Cleaning methods selected for a particular component shall be consistent with the contaminants to be removed and shall not be detrimental to the component itself or its intended function. All cleaning materials must be approved for use by the appropriate Fairchild Maintenance Manual, Structural Repair Manual, or Component Maintenance Manual.
- C. Conduct the inspection at the required locations as referenced by the specific nondestructive inspection procedure. Scan the inspection area at width increments that do not exceed the width of the eddy-current test coil. Wherever possible, the areas to be inspected using surface eddy current shall be scanned in two different directions. The scans shall be conducted at scan paths 90 degrees to each other. All areas that require bolt hole eddy-current inspection shall be scanned for the entire depth of the hole. The bolt hole probe index rate shall not exceed the width of the eddy-current test coil.
- D. If an indication is detected, carefully repeat the inspection in the opposite direction of probe movement to verify the indication. If the indication persists, carefully monitor the amount of probe movement or rotation required to cause the instrument to move off the maximum indication response.

2. Equipment

- A. In the development of the eddy-current inspection techniques contained in this manual, the eddy-current inspection equipment listed in the individual procedure was utilized. Equivalent eddy-current test equipment may be used provided the equipment is capable of achieving the required frequency range and test sensitivity. When substitute equipment is used, it may be necessary to make adjustments to the established techniques.

FAIRCHILD AEROSPACE
SA226 & SA227 SERIES
SUPPLEMENTAL INSPECTION DOCUMENT

GENERAL FLUORESCENT LIQUID PENETRANT INSPECTION

1. General

- A. Fluorescent liquid penetrant inspection is effective in detecting small cracks or discontinuities open to the surface which may not be evident by normal visual inspection. Liquid penetrant inspection can be used on most airframe parts and assemblies accessible for its application. The inspection is performed by applying a liquid which penetrates into surface discontinuities. Excessive penetrant is removed and a suitable developer is applied to draw the penetrant from the surface discontinuities. Visual indications are obtained by the fluorescence of the penetrant under the display of ultraviolet light.
- B. The inspection area must be clean and dry and free of dirt, grease, paint, or any other contaminants which would interfere with the liquid penetrant inspection. Cleaning and paint removal methods selected for a particular component shall be consistent with the contaminants to be removed and shall not be detrimental to the component or its intended function. All cleaning materials must be approved for use by the appropriate Fairchild Maintenance Manual, Structural Repair Manual, Component Maintenance Manual, or Nondestructive Testing Manual.
- C. Fluorescent liquid penetrant shall be accomplished in accordance with the procedures contained or referenced in the Supplemental Inspection Document. ASTM E1417, Standard Practice for Liquid Penetrant Examination, shall be consulted for the general requirements for liquid penetrant inspection. In the event of a conflict between the text of the Supplemental Inspection Document and ASTM E1417, the text of the Supplemental Inspection Document shall take precedence.

2. Materials and Equipment

- A. Fluorescent penetrant is the required inspection method when liquid penetrant inspection is specified in the Supplemental Inspection Document. Fluorescent penetrant inspection has a high sensitivity and the ability to detect small fatigue cracks open to the surface. Visible dye penetrant does not have the required sensitivity and shall not be used for the inspection of aircraft.
- B. Only materials approved for listing on QPL-25135 (refer to MIL-I-25135) shall be used for penetrant inspection. All materials shall be from the same family group. Interchanging or mixing of penetrant cleaners, penetrant materials, or developers from different manufacturers is prohibited.
- C. Penetrant materials are defined by specific classifications per MIL-I-25135 and must meet or exceed the classification listed below.
 - i. Type 1 (Fluorescent)
 - ii. Level 3 (High Sensitivity)
 - iii. Method C (Solvent Removable)

CAUTION: Type II (visible dye) penetrant shall not be used for the inspection of aircraft and aircraft components.

FAIRCHILD AEROSPACE
SA226 & SA227 SERIES
SUPPLEMENTAL INSPECTION DOCUMENT

GENERAL MAGNETIC PARTICLE INSPECTION

1. General

- A. Magnetic particle inspection is a nondestructive inspection method for revealing surface and near surface discontinuities in parts made of magnetic materials. Alloys which contain a high percentage of iron and can be magnetized make up the ferromagnetic class of metals. The magnetic particle inspection method will detect surface discontinuities including those that are too fine to be seen with the unaided eye and those that lie slightly below the surface. The magnetic particle inspection method consists of three basic operations:
 - i. Establishment of a suitable magnetic field.
 - ii. Application of magnetic particles.
 - iii. Examination and evaluation of the particle accumulations.
- B. Electrical current is used to create or induce magnetic fields into the material. The direction of the magnetic field can be altered and is controlled by the direction of the magnetizing current. The arrangement of the current paths is used to induce the magnetic lines of force so they intercept a discontinuity at a transverse direction. When a magnetic field within a part is interrupted by a discontinuity, some of the field is forced out into the air above the discontinuity. The presence of a discontinuity is detected by the application of finely divided fluorescent ferromagnetic particles to the surface of the part. Some of the particles will be gathered and held by the leakage field. The magnetically held collection of particles forms an outline of the discontinuity and indicates its location, size, and shape.
- C. Magnetic particle inspection shall be accomplished in accordance with the procedures contained or referenced in the Supplemental Inspection Document. ASTM E1444, Standard Practice for Magnetic Particle Examination, shall be consulted for general requirements for magnetic particle inspection. In the event of a conflict between the text of the Supplemental Inspection Document and ASTM 1444, the text of the Supplemental Inspection Document shall take precedence.

2. Materials and Equipment

- A. Fluorescent magnetic particle inspection has a high sensitivity and the ability to detect small fatigue cracks. Visible dry magnetic particles do not have the required sensitivity and shall not be used for inspection of aircraft.
- B. The specific magnetic particle equipment required to accomplish an inspection will be specified for each procedure contained in this manual.

CAUTION: CONTACT PRODS SHALL NOT BE USED ON AIRCRAFT COMPONENTS OR PARTS.

FAIRCHILD AEROSPACE
SA226 & SA227 SERIES
SUPPLEMENTAL INSPECTION DOCUMENT

GENERAL RADIOGRAPHY INSPECTION

1. General

- A. Radiographic inspection is a nondestructive inspection method used for the inspection of aircraft structure inaccessible or unsatisfactory for the application of other nondestructive test methods. Radiographic inspection will show internal and external structural details of all types of parts and materials. The inspection is accomplished by passing radiation through the part or assembly to expose the radiographic film. The processed film shows the structural details of the part or assembly by variations in film density.

2. Materials and Equipment

- A. The use of radiation in nondestructive inspection presents a potential hazard to operating and adjacent personnel unless all safety precaution and protective requirements are observed. Information on radiation protection can be found in the Code of Federal Regulations, Title 10, Parts 19, 20, and 34.6.1.2.

3. Abbreviations

KV = Kilovolts	MAM = Millampere minutes
SFD = Source to Film Distance	MAS = Millampere seconds

4. Requirements

- A. Radiographic inspection shall be accomplished in accordance with the procedures contained or referenced in the Supplemental Inspection Document. ASTM E1742, Standard Practice for Radiographic Examination, shall be consulted for the general requirements for radiographic inspection. In the event of a conflict between the text of the Supplemental Inspection Document and ASTM E1742, the text of the Supplemental Inspection Document shall take precedence.
- B. Optimum densities are given for each inspection technique contained in this manual; however, densities below 1.5 and above 3.7 are unacceptable for the radiographic examination of this aircraft.

NOTE: Settings specified in individual radiographic procedures in this manual were established to provide quality radiographs. It may be necessary to vary the MA time and KV setting due to differences in equipment, film, and method of processing in order to achieve the contrast, sensitivity, and density specified. X-ray equipment is considered acceptable provided it produces the quality radiographs specified for the procedures contained in this manual.

CAUTION: THE USE OF RADIOACTIVE ISOTOPES FOR RADIOGRAPHIC INSPECTION IS PROHIBITED.

FAIRCHILD AEROSPACE
SA226 & SA227 SERIES
SUPPLEMENTAL INSPECTION DOCUMENT

TITLE

SUPPLEMENTAL INSPECTION NUMBER: 52-31-01

SA226/SA227 Cargo Door Hinge

EFFECTIVITY

SA226 – All
SA227 – All

DESCRIPTION

Inspect for fatigue cracks in the cargo door hinge tabs and skin around fastener holes.

PREPARATION

1. Clean the inspection area with solvent to remove dirt, grease, oil, and other substances that may interfere with the inspection.

INSPECTION METHOD

Surface Eddy Current

CRACK SIZE

Minimum detectable crack size: 0.10 inch

EQUIPMENT

The following equipment is recommended to perform the inspection. Equivalent eddy-current test equipment may be used provided that the equipment is capable of achieving the required frequency range and sensitivity.

- 100- to 500-kHz shielded absolute metal shaft probe, NORTEC stock no. 9213013. Note: this probe requires a separate cable.

INSPECTION INSTRUCTIONS

1. Adhere to procedures for Eddy-Current Inspection given in the SA226/227/227CC Structural Repair Manual, Chapter 51-30-07.
2. Refer to Figure 1. Inspect the hinge tabs and around fastener holes along the length of the hinge. Inspect the top piece (on fuselage) and bottom piece (on cargo door). Observe the phase and amplitude changes on the instrument.
3. Cracks are most likely to occur near the ends of the hinge.
4. If an indication is noted, carefully repeat the inspection pass in the opposite direction to verify the indication.
5. All cracks detected shall be reported to Fairchild Service Engineering. Report the location, direction, and length of each crack.

FAIRCHILD AEROSPACE
SA226 & SA227 SERIES
SUPPLEMENTAL INSPECTION DOCUMENT

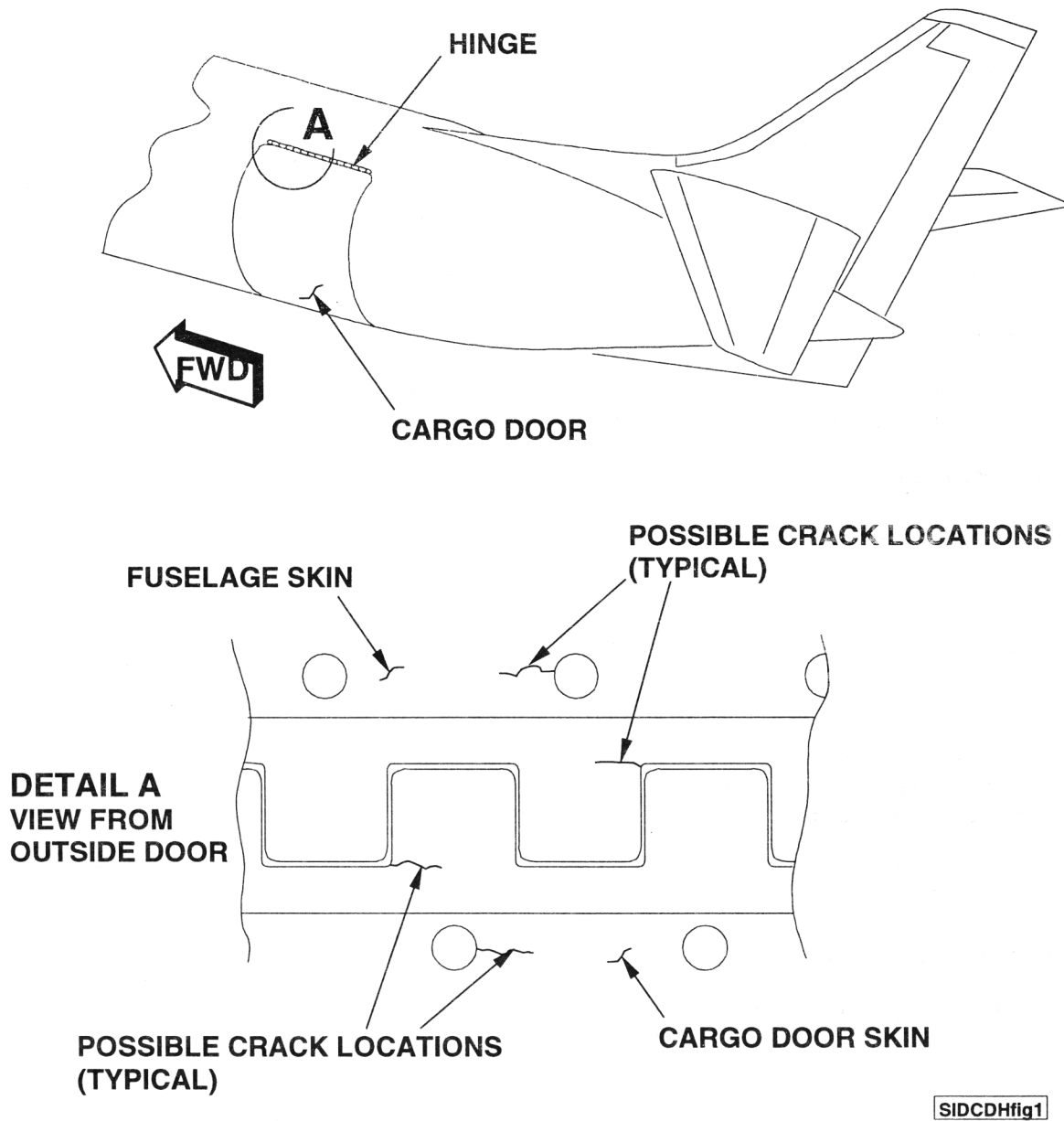

Figure 1. SA226/SA227 Cargo Door Hinge

FAIRCHILD AEROSPACE
SA226 & SA227 SERIES
SUPPLEMENTAL INSPECTION DOCUMENT

TITLE

SUPPLEMENTAL INSPECTION NUMBER: 57-10-01

SA226 Wing Main Spar Lower Cap at Station 99

EFFECTIVITY

SA226 - All

DESCRIPTION

Inspect for fatigue cracks in the aluminum extrusions of the main spar lower cap at station 99.

PREPARATION

1. Remove sealant and other contaminants from those surfaces of the aluminum spar cap extrusions between stations 96 and 111 that are not hidden by other parts. These surfaces include the following: the fwd edges of the cap and fwd angle, the aft edges of the cap and aft angle, the vertical legs of the fwd and aft angles, and the bottom of the cap protrusion from the wing skin. Refer to Figure 1.
2. Clean the inspection area with solvent to remove dirt, grease, oil, and other substances that may interfere with the inspection. Refer to Figure 1.

INSPECTION METHOD

Surface Eddy Current

CRACK SIZE

Minimum detectable crack size: 0.10 inch

EQUIPMENT

The following equipment is recommended to perform the inspection. Equivalent eddy current test equipment may be used provided that the equipment is capable of achieving the required frequency range and sensitivity.

- 100- to 500-kHz shielded absolute metal shaft probe, NORTEC stock no. 9213013. Note: this probe requires a separate cable.

INSPECTION INSTRUCTIONS

1. Adhere to procedures for Eddy-Current Inspection given in the SA226/227 Structural Repair Manual, Chapter 51-30-07.
2. Refer to Figure 1. Inspect the exposed surfaces of the aluminum spar cap extrusions between stations 96 and 111, left and right wing. Observe the phase and amplitude changes on the instrument.
3. Cracks are most likely to occur at station 99, just inboard of where the titanium straps end.
4. Stations with fasteners are more likely to have cracks than stations without fasteners.
5. Detection of a crack may indicate complete failure of the part.

FAIRCHILD AEROSPACE
SA226 & SA227 SERIES
SUPPLEMENTAL INSPECTION DOCUMENT

6. If an indication is noted, carefully repeat the inspection pass in the opposite direction to verify the indication.
7. All cracks detected shall be reported to Fairchild Service Engineering. Report the location, direction, and length of each crack.

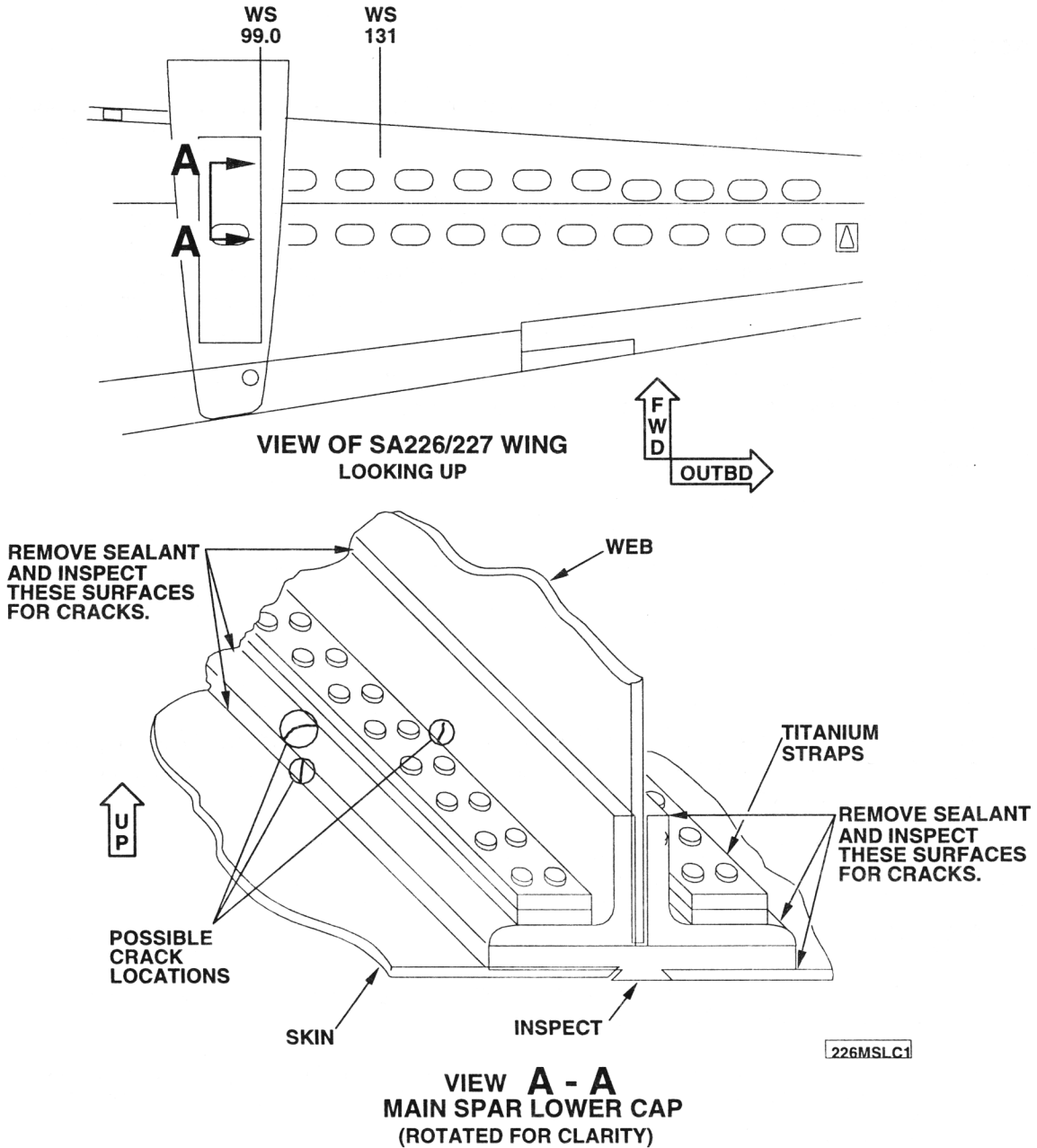

FIGURE 1. SA226/227 WING MAIN SPAR LOWER CAP WS 99

FAIRCHILD AEROSPACE
SA226 & SA227 SERIES
SUPPLEMENTAL INSPECTION DOCUMENT

TITLE

SUPPLEMENTAL INSPECTION NUMBER: 57-10-02

SA226 Wing Main Spar Lower Cap at Station 9

EFFECTIVITY

SA226 - T 201-275, T 277-291, T(B) 276, T(B) 292-393 except 303E, TC 201-397, AT 001-074 except 070

DESCRIPTION

Inspect for fatigue cracks in the aluminum extrusions of the main spar lower cap at station 9.

PREPARATION

1. Clean the inspection area with solvent to remove dirt, grease, oil, and other substances that may interfere with the inspection. The inspection area includes the following surfaces between stations 8 and 13: the fwd edges of the cap and fwd angle, the aft edges of the cap and aft angle, the vertical legs of the fwd and aft angles, and the bottom of the cap protrusion from the wing skin. Refer to Figure 1.

INSPECTION METHOD

Surface Eddy Current

CRACK SIZE

Minimum detectable crack size: 0.10 inch

EQUIPMENT

The following equipment is recommended to perform the inspection. Equivalent eddy-current test equipment may be used provided that the equipment is capable of achieving the required frequency range and sensitivity.

- 100- to 500-kHz shielded absolute metal shaft probe, NORTEC stock no. 9213013. Note: this probe requires a separate cable.

INSPECTION INSTRUCTIONS

1. Adhere to procedures for Eddy Current Inspection given in the Sa226/227 Structural Repair Manual, Chapter 51-30-07.
2. Refer to Figure 1 of SIN 57-10-1. Inspect the aluminum spar cap extrusions between stations 8 and 13, left and right wing. Observe the phase and amplitude changes on the instrument.
3. Stations with fasteners are more likely to have cracks than stations without fasteners.
4. Detection of a crack may indicate complete failure of the part.
5. If an indication is noted, carefully repeat the inspection pass in the opposite direction to verify the indication.
6. All cracks detected shall be reported to Fairchild Service Engineering. Report the location, direction, and length of each crack.

FAIRCHILD AEROSPACE
SA226 & SA227 SERIES
SUPPLEMENTAL INSPECTION DOCUMENT

TITLE

SUPPLEMENTAL INSPECTION NUMBER: 57-10-04

SA226 Wing Rear Spar Lower Cap at Station 27

EFFECTIVITY

SA226 - All

DESCRIPTION

Inspect for fatigue cracks in the aft aluminum angle of the rear spar lower cap at station 27.

PREPARATION

1. Clean the inspection area with solvent to remove dirt, grease, oil, and other substances that may interfere with the inspection.

INSPECTION METHOD

Surface Eddy Current

CRACK SIZE

Minimum detectable crack size: 0.10 inch

EQUIPMENT

The following equipment is recommended to perform the inspection. Equivalent eddy current test equipment may be used provided that the equipment is capable of achieving the required frequency range and sensitivity.

- 100 to 500 KHz shielded absolute metal shaft probe, NORTEC stock no. 9213013. Note: this probe requires a separate cable.

INSPECTION INSTRUCTIONS

1. Adhere to procedures for Eddy-Current Inspection given in the SA226/227 Structural Repair Manual, Chapter 51-30-07.
2. Refer to Figure 1. Inspect aft aluminum spar cap angle around the fastener holes between stations 24 and 27, left and right wing. Observe the phase and amplitude changes on the instrument.
3. If an indication is noted, carefully repeat the inspection pass in the opposite direction to verify the indication.
4. All cracks detected shall be reported to Fairchild Service Engineering. Report the location, direction, and length of each crack.

FAIRCHILD AEROSPACE
SA226 & SA227 SERIES
 SUPPLEMENTAL INSPECTION DOCUMENT

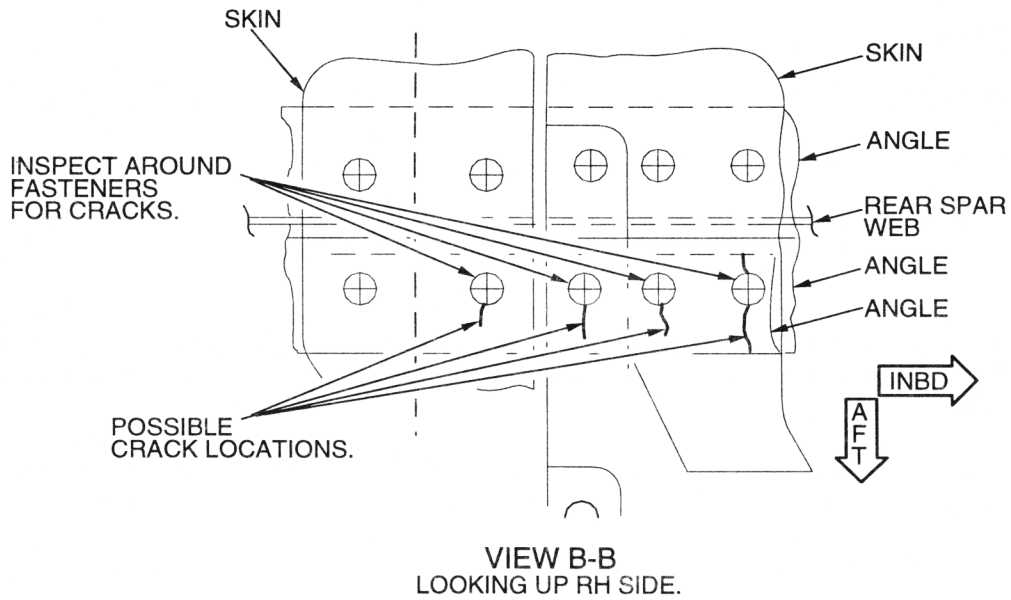
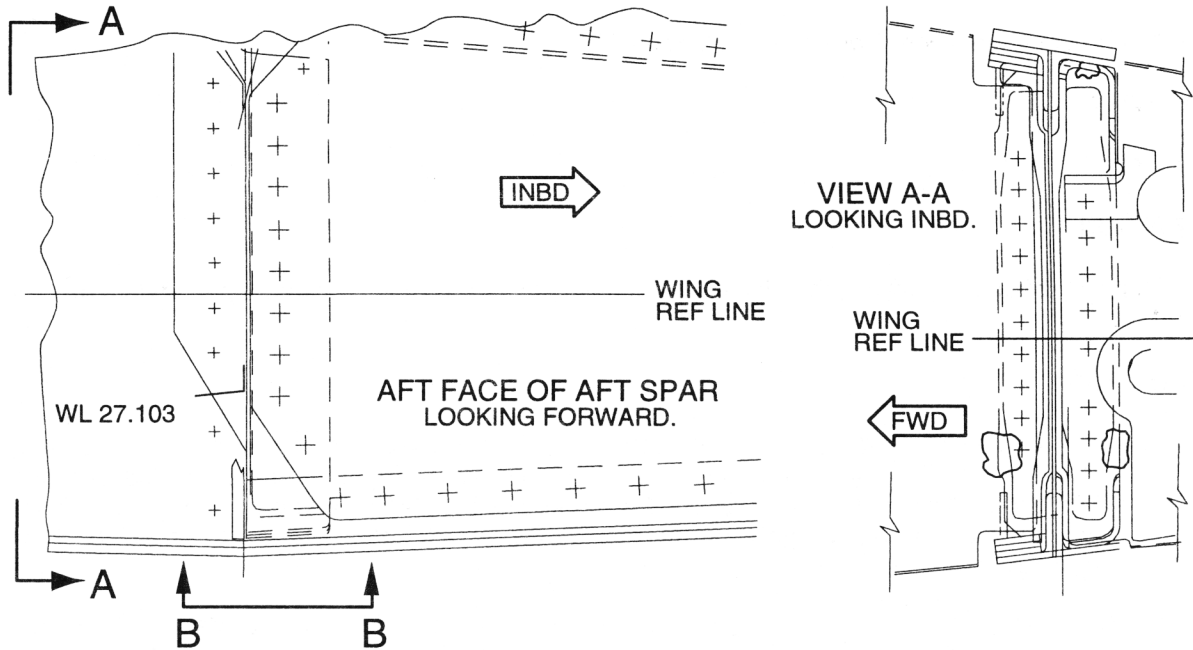

226RSLC1

SA226 WING REAR SPAR LOWER CAP AT WS 27
 FIGURE 1

FAIRCHILD AEROSPACE
SA226 & SA227 SERIES
SUPPLEMENTAL INSPECTION DOCUMENT

TITLE

SUPPLEMENTAL INSPECTION NUMBER: 57-10-05

SA227 Wing Main Spar Lower Cap at Station 99

EFFECTIVITY

SA227 – All

DESCRIPTION

Inspect for fatigue cracks in the aluminum extrusions of the main spar lower cap at station 99 and 130.

PREPARATION

1. Remove sealant and other contaminants from those surfaces of the aluminum spar cap extrusions between stations 96 and 133 that are not hidden by other parts. These surfaces include the following: the fwd edges of the cap and fwd angle, the aft edges of the cap and aft angle, the vertical legs of the fwd and aft angles, and the bottom of the cap protrusion from the wing skin. Refer to Figure 1.
2. Clean the area with solvent to remove dirt, grease, oil, and other substances that may interfere with the inspection. Inspection forward and aft side of the spar. Refer to Figure 1.

INSPECTION METHOD

Surface Eddy Current

CRACK SIZE

Minimum detectable crack size: 0.10 inch

EQUIPMENT

The following equipment is recommended to perform the inspection. Equivalent eddy current test equipment may be used if the equipment is capable of achieving the required frequency range and sensitivity.

- 100 to 500 kHz shielded absolute metal shaft probe, NORTEC stock no. 9213013. Note: this probe requires a separate cable.

INSPECTION INSTRUCTIONS

1. Adhere to procedures for Eddy Current Inspection given in the SA226/227/227CC Structural Repair Manual, Chapter 51-30-07.
2. Refer to Figure 1. Inspect the exposed surfaces of the aluminum spar cap extrusions between stations 96 and 133, left and right wing. Observe the phase and amplitude changes on the instrument.
3. Cracks are most likely to occur at stations 99 and 130.
4. Stations with fasteners are more likely to have cracks than stations without fasteners.

FAIRCHILD AEROSPACE
SA226 & SA227 SERIES
 SUPPLEMENTAL INSPECTION DOCUMENT

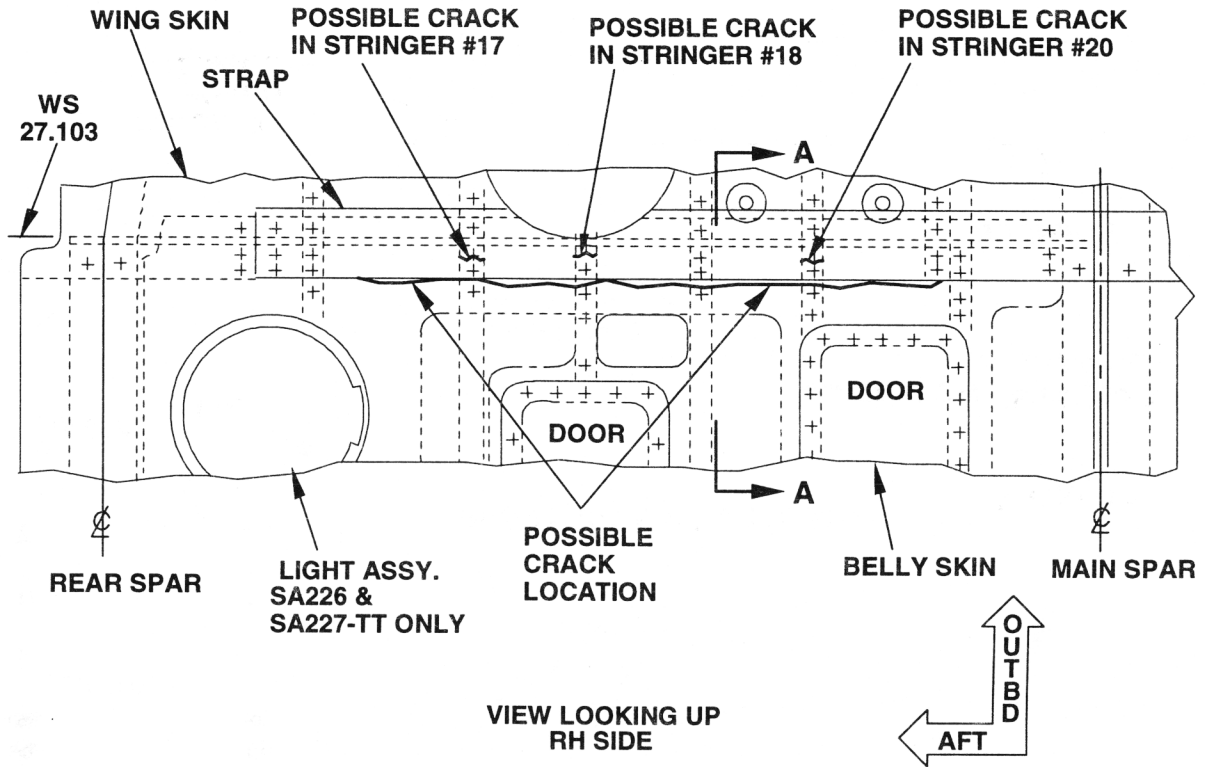

SI DI ws27f1-3

Figure 1. SA226/SA227 Lower Wing Skin Splice at WS 27 (Sheet 1)

FAIRCHILD AEROSPACE
SA226 & SA227 SERIES
 SUPPLEMENTAL INSPECTION DOCUMENT

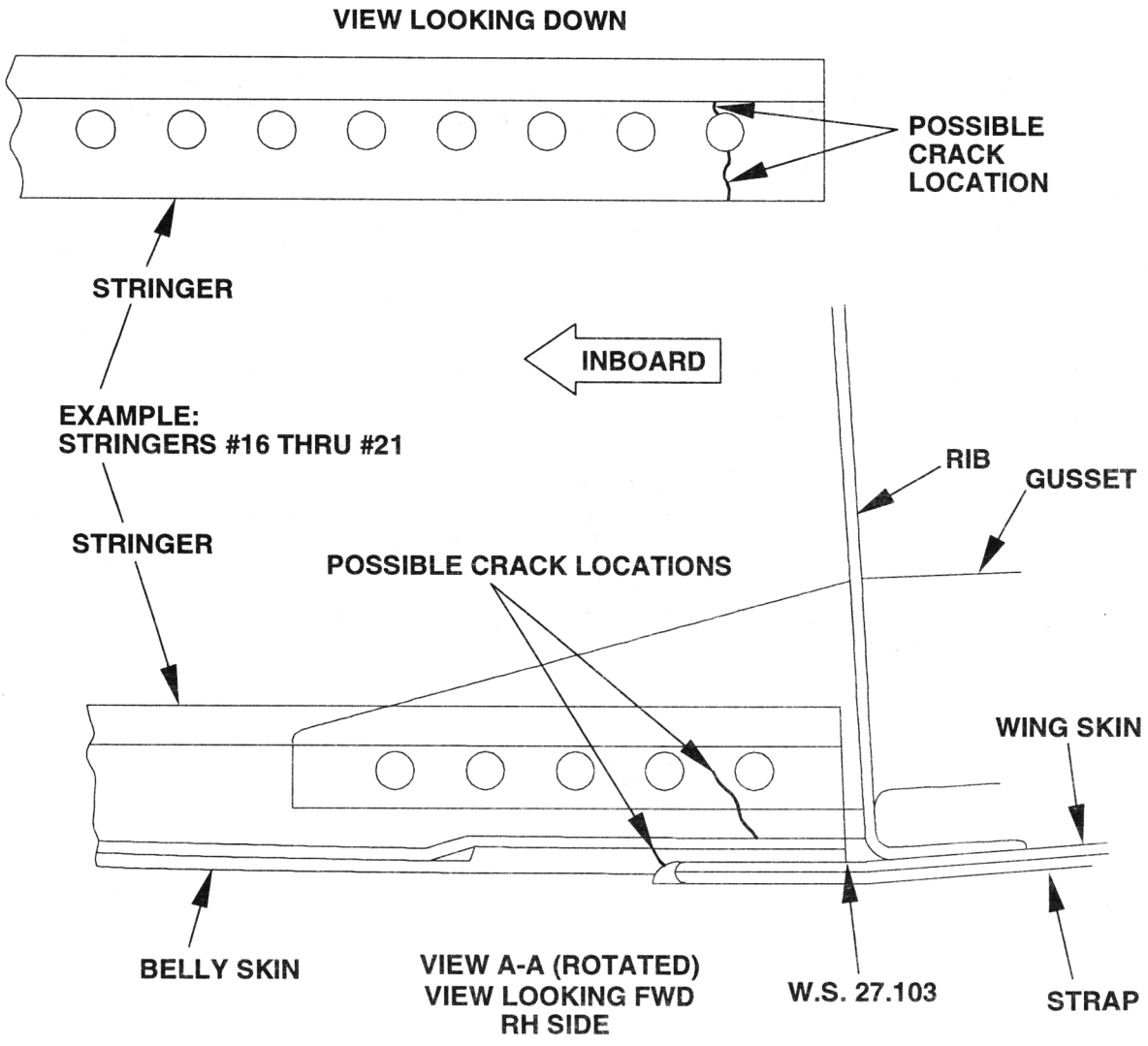

SIDlws27f1-2

Figure 1. SA226/SA227 Lower Wing Skin Splice at WS 27 (Sheet 2)

FAIRCHILD AEROSPACE
SA226 & SA227 SERIES
SUPPLEMENTAL INSPECTION DOCUMENT

TITLE

SUPPLEMENTAL INSPECTION NUMBER: 57-10-07

SA226/SA227 Wing Lower Center Section Skin at Landing Light Cutout

EFFECTIVITY

SA226 – All
SA227-TT - All

DESCRIPTION

Inspect for fatigue cracks in belly skin around the landing light cutout.

PREPARATION

1. Clean the inspection area with solvent to remove dirt, grease, oil, and other substances that may interfere with the inspection.

INSPECTION METHOD

Surface Eddy Current

CRACK SIZE

Minimum detectable crack size: 0.15 inch

EQUIPMENT

The following equipment is recommended to perform the inspection. Equivalent eddy current test equipment may be used provided that the equipment is capable of achieving the required frequency range and sensitivity.

- 100- to 500-kHz shielded absolute metal shaft probe, NORTEC stock no. 9213013. Note: this probe requires a separate cable.

INSPECTION INSTRUCTIONS

1. Adhere to procedures for Eddy-Current Inspection given in the SA226/227 Structural Repair Manual, Chapter 51-30-07.
2. Refer to Figure 1. Inspect belly skin around landing light cutout and at splice of belly skin to center wing skin. Observe the phase and amplitude changes on the instrument.
3. If an indication is noted, carefully repeat the inspection pass in the opposite direction to verify the indication.
4. All cracks detected shall be reported to Fairchild Field Support Engineering. Report the location, direction, and length of each crack.

FAIRCHILD AEROSPACE
SA226 & SA227 SERIES
SUPPLEMENTAL INSPECTION DOCUMENT

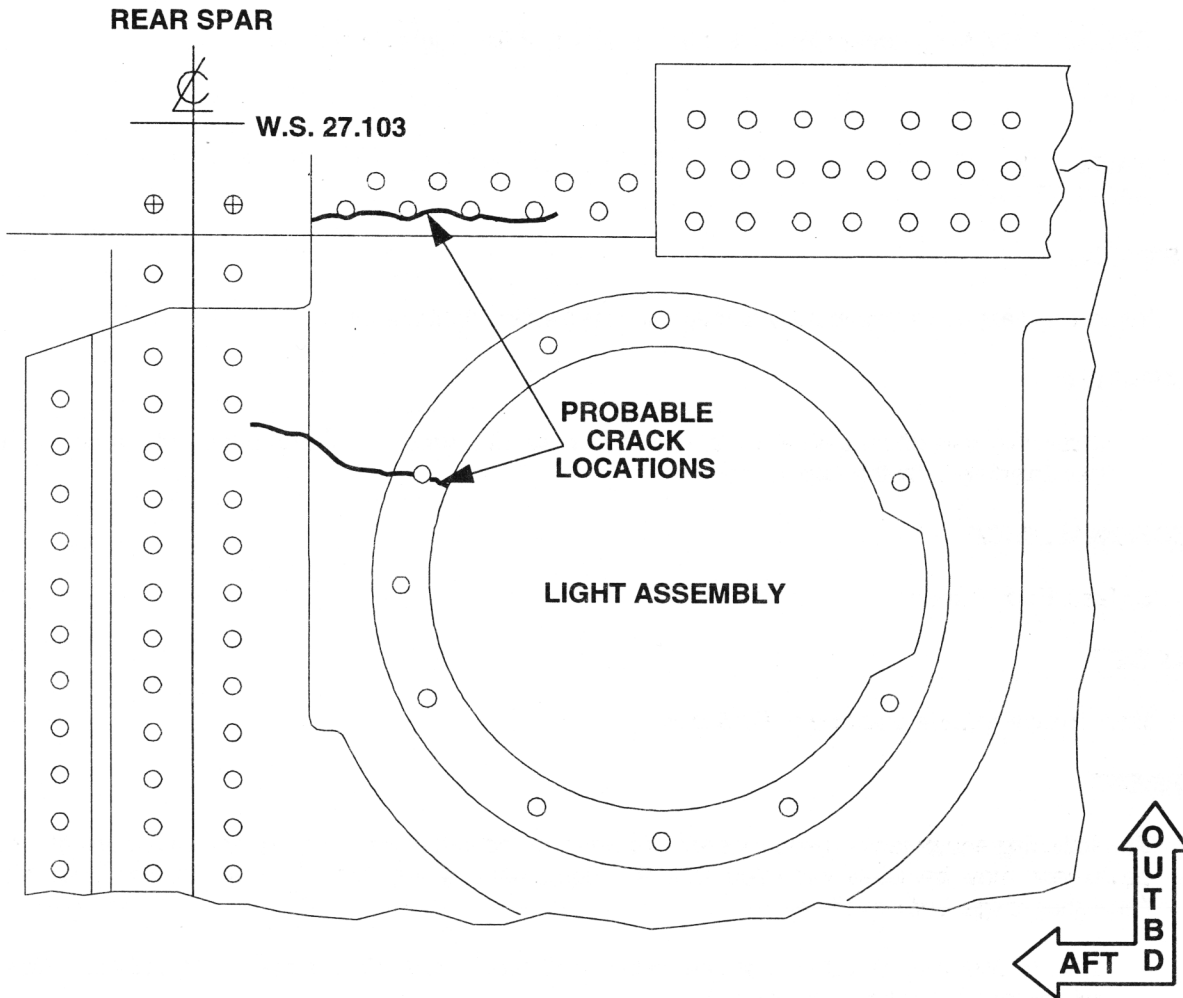

SID226WLC11

Figure 1. SA226/SA227 Wing Center Section Skin at Landing Light Cutout

FAIRCHILD AEROSPACE
SA226 & SA227 SERIES
SUPPLEMENTAL INSPECTION DOCUMENT

TITLE

SUPPLEMENTAL INSPECTION NUMBER: 71-21-01

SA227 Engine Mount at Firewall

EFFECTIVITY

SA227 – All airplanes with 27-62114 engine mount truss, except S/N 892, 893, and 895 and up.

DESCRIPTION

Inspect for fatigue cracks in end plate and at weld of end plate to tubing.

PREPARATION

1. Clean the inspection area with solvent to remove dirt, grease, oil, and other substances that may interfere with the inspection.
2. Remove paint and primer from the inspection area using an approved chemical paint stripper.

INSPECTION METHOD

Fluorescent Penetrant

CRACK SIZE

Minimum detectable crack size: 0.10 inch

EQUIPMENT

The following materials are recommended to perform the inspection. Equivalent materials may be used provided they have Type 1, Level 3 sensitivity and are capable of achieving the requirements listed in the General section, Fluorescent Penetrant Inspection, of this SID.

- General Purpose Zyglo Kit, ZA-59, P/N 602585.

INSPECTION INSTRUCTIONS

1. Adhere to procedures for Fluorescent Penetrant Inspection given in the SA226/227/227CC Structural Repair Manual, Chapter 51-30-07.
2. Refer to Figure 1. Inspect end plate at both upper mount points on truss. Inspect face of end plate and where end plate is welded to tubing, as shown in Figure 1.
3. All cracks detected shall be reported to Fairchild Field Support Engineering. Report the location, direction, and length of each crack.
4. If no cracks are found, prime and paint stripped areas in accordance with SA226/227/227CC Structural Repair Manual. Do not prime or paint mating surface of end plate where it contacts firewall.

FAIRCHILD AEROSPACE
SA226 & SA227 SERIES
SUPPLEMENTAL INSPECTION DOCUMENT

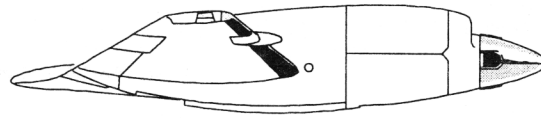

LH/RH ENGINE

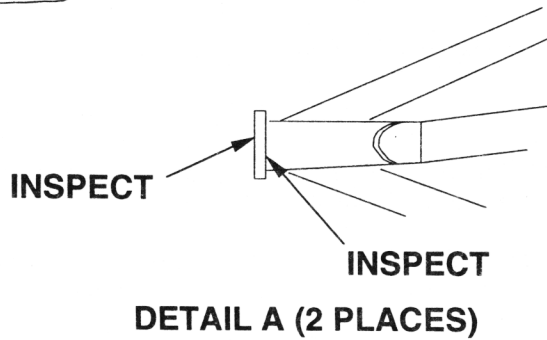
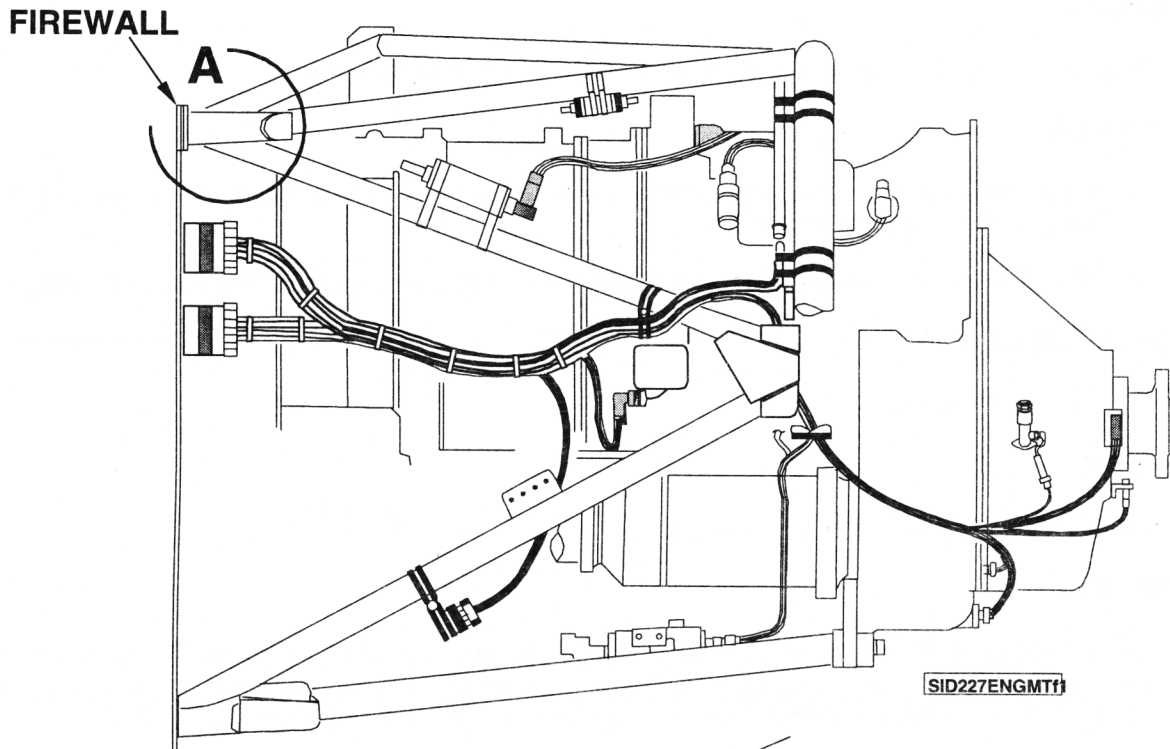

Figure 1. SA227 Engine Mount at Firewall