

## Chapter 8 Oil Burner Test for Cargo Liners

### 8.1 Scope

- 8.1.1 This test method evaluates the flame penetration resistance capabilities of aircraft cargo compartment lining materials utilizing a high-intensity open flame to show compliance to the requirements of FAR 25.855.

### 8.2 Definitions

- 8.2.1 Burnthrough

Burnthrough is defined as flame penetration of the test specimen.

- 8.2.2 Specimen Set

A specimen set consists of three or more replicates of a ceiling and sidewall cargo liner panel installation.

### 8.3 Apparatus

- 8.3.1 Test Specimen Frame

The test specimen frame is shown in figures 8-1 through 8-3. The burner will be mounted on a swiveling device capable of allowing it to be directed away from the test specimen during warmup.

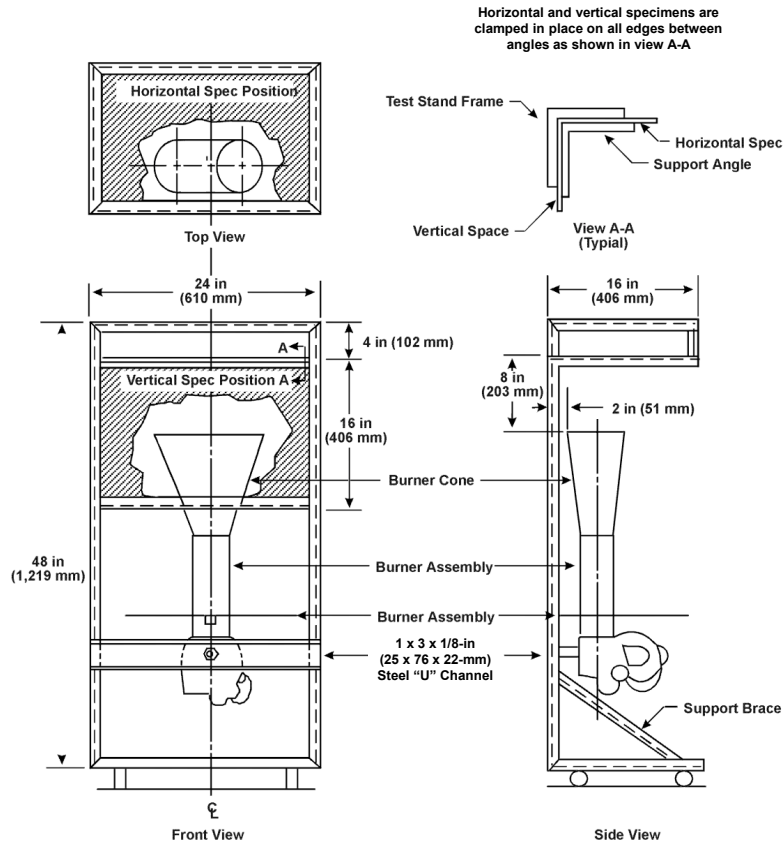

Figure 8-1. Test Apparatus for Horizontal and Vertical Mounting for Cargo Liner Oil Burner Testing

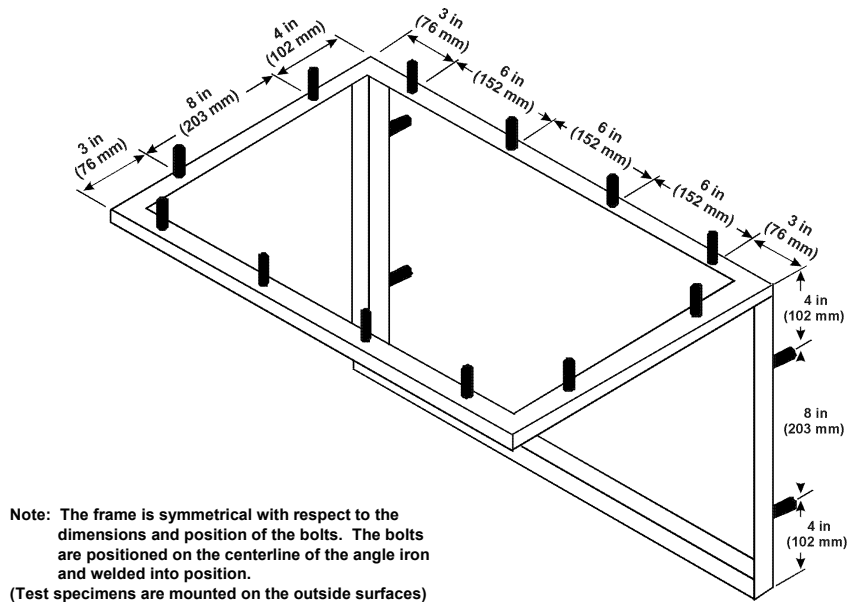

Figure 8-2. Cargo Liner Test Specimen Frame

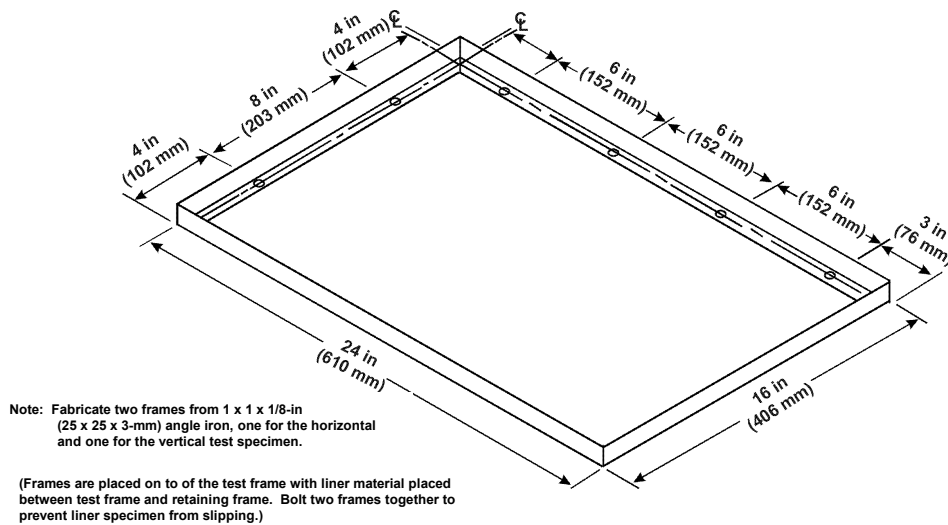

Figure 8-3. Cargo Liner Test Specimen Retaining Frame

### 8.3.2 Test Burner

The burner will be a modified gun type, such as Park Model DPL 3400, Lennox Model OB-32, or Carlin Model 200 CRD. Flame characteristics can be enhanced by the optional use of a static disk or tabs. Major deviations, such as a different burner type, should have thorough comparison testing. Temperature and heat flux measurements, as well as test results, must correspond to those produced by an FAA approved burner.

#### 8.3.2.1 Nozzle

A nozzle will be provided to maintain the fuel pressure to yield a nominal  $2 \pm 0.1$  gal/hr ( $0.126 \pm 0.0063$  liter/min) fuel flow (see Chapter 8 Supplement).

### 8.3.2.2 Burner Cone

A  $12 \pm 1/8$ -inch ( $305 \pm 3$ -mm) burner cone will be installed at the end of the draft tube. The cone will be made of stainless steel or a similar type of noncorrosive high-temperature metal and will have a thickness of  $0.065 \pm 0.015$  inch ( $1.65 \pm 0.375$  mm). The opening of the cone will be  $6 \pm 1/4$  inches ( $152 \pm 6$  mm) high and  $11 \pm 1/4$  inches ( $280 \pm 6$  mm) wide (see figures 8-4a and 8-4b).

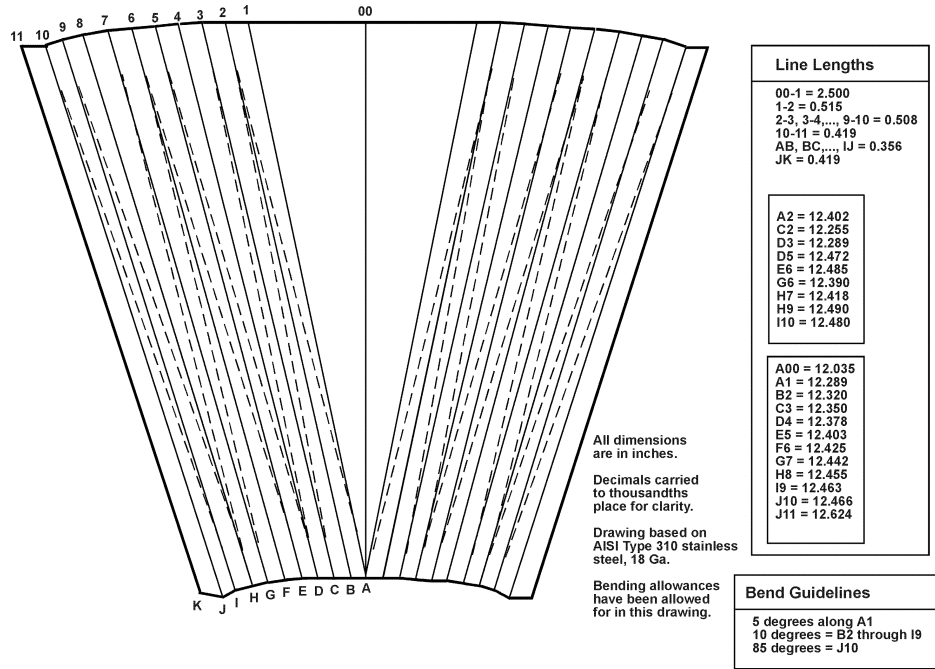

Figure 8-4a. Burner Cone Layout and Bending Pattern

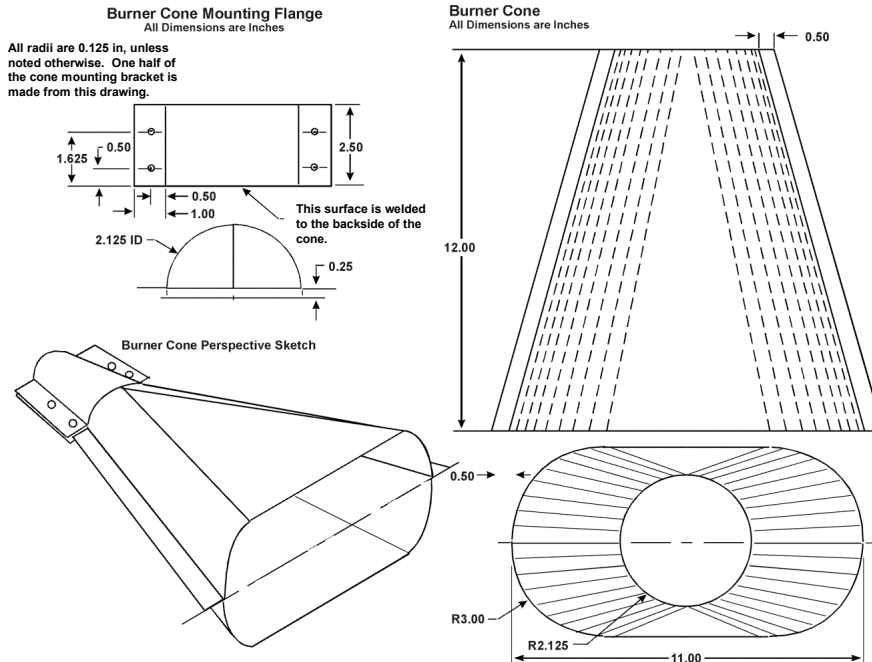

Figure 8-4b. Burner Cone Details

### 8.3.2.3 Fuel Pressure Regulator

A fuel pressure regulator, adjusted to deliver 2 gal/hr  $\pm$  0.1 gal/hr (0.126 liter/min), will be provided (see Chapter 8 Supplement).

### 8.3.2.4 Fuel

Either number 2 Grade kerosene or American Society for Testing and Materials (ASTM) D2 fuel (number 2 Grade fuel oil) will be used.

### 8.3.2.5 Burner Airflow

Adjust the shutter to attain an airflow of 67  $\pm$  4 ft<sup>3</sup>/min (1.89  $\pm$  0.011 m<sup>3</sup>/min). See paragraph 8.3.5.2 of Chapter 8 Supplement.

## 8.3.3 Calorimeter

The calorimeter will be a total heat flux density, foil type Gardon Gauge of an appropriate range, such as 0-15 Btu/(ft<sup>2</sup> second) (0-17 W/cm<sup>2</sup>), accurate to  $\pm$  3 percent of the indicated reading.

### 8.3.3.1 Calorimeter Mounting

The calorimeter will be mounted in a 6 by 12  $\pm$  1/8-inch (152 by 305  $\pm$  3-mm) by 3/4-inch (19-mm) -thick insulating block that is attached to a steel angle bracket for placement in the test stand during burner calibration (see figure 8-5). The insulating block will be monitored for deterioration and the mounting shimmed as necessary to ensure that the calorimeter face is parallel to the exit plane of the test burner cone.

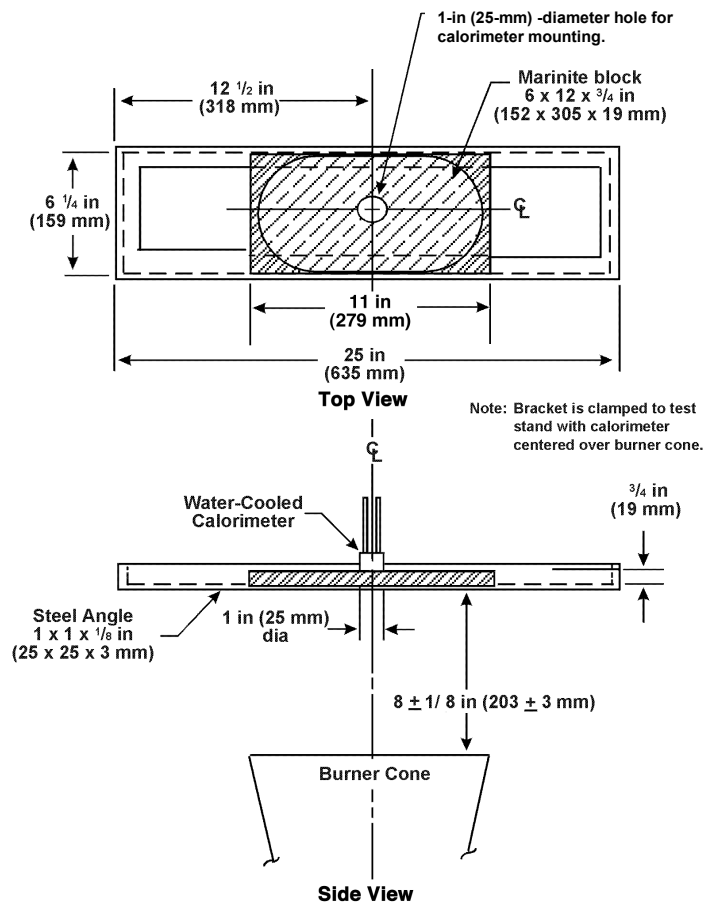

Figure 8-5. Top and Side Views of Calorimeter Bracket

### 8.3.4 Thermocouples

The seven thermocouples to be used for calibration will be 1/16-inch (1-mm) ceramic packed, metal sheathed, type K (Chromel-Alumel), grounded junction thermocouples with a nominal 30 AWG size conductor. The seven thermocouples will be attached to a steel angle bracket to form a thermocouple rake for placement in the test stand during burner calibration, as shown in figure 8-6.

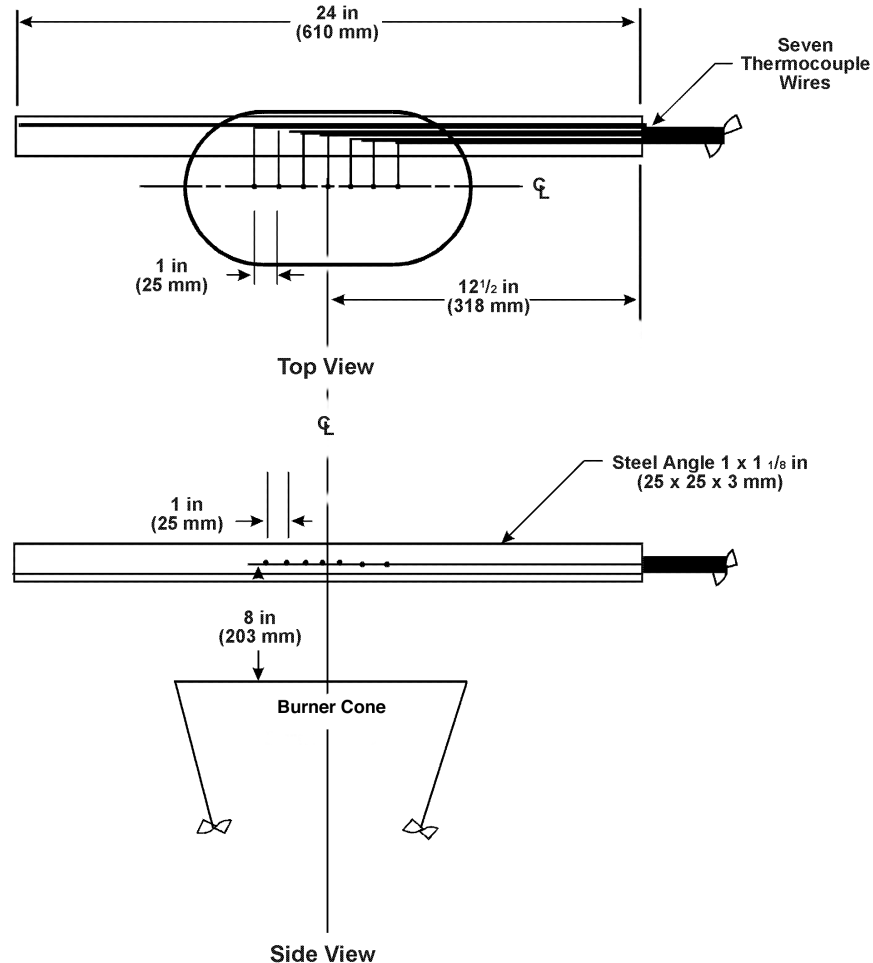

Figure 8-6. Top and Side View of Thermocouple Rake Bracket

### 8.3.5 Instrumentation

A calibrated recording device or a computerized data acquisition system with an appropriate range will be provided to measure and record the outputs of the calorimeter and the thermocouples.

#### 8.3.5.1 Timing Device

A stopwatch or other device, accurate to within 1 second/hour, will be provided to measure the time of application of the burner flame, the material flaming time, and the burnthrough time.

#### 8.3.5.2 Anemometer

A vane-type air velocity sensing unit will be used to monitor the flow of air at the inlet of the oil burner. The inlet will be completely sealed except for an opening for the air velocity

sensor where the inlet will be centered and mounted. See the anemometer setup in figure 8-7.

## 8.4 Test Specimen(s)

### 8.4.1 Specimen Configuration

Each cargo liner panel type and design configuration will be tested. Design configuration includes cargo compartment design features such as corners, joints, seams, lamp assemblies, pressure relief valves, temperature sensors, etc., that may affect the capability of a cargo compartment to safely contain a fire.

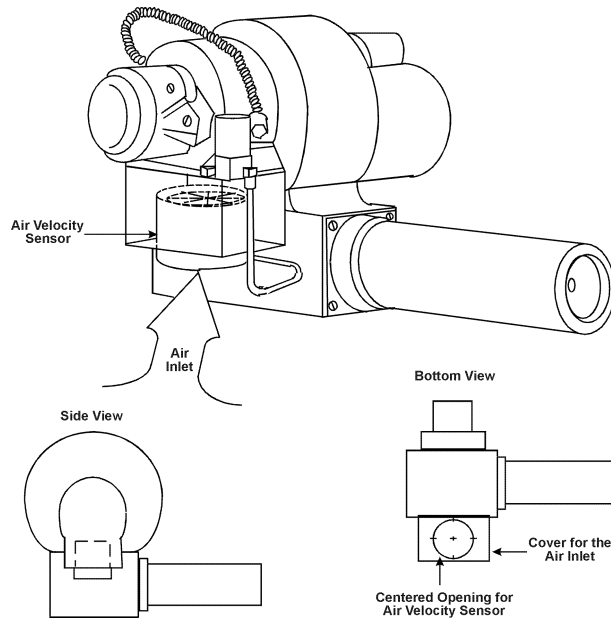

Figure 8-7. Illustration for the Location of the Air Velocity Sensor

8.4.1.1 Ceiling and sidewall liner panels may be tested individually provided a baffle of fire-resistant material, such as Kaowool or Marinite, is used to simulate the missing panel.

### 8.4.2 Specimen Number

A minimum of three specimens or specimen sets for each panel type or design configuration will be prepared for testing.

### 8.4.3 Specimen Size

The specimens to be tested will measure  $16 \pm 1/8$  inches ( $406 \pm 3$  mm) by  $24 \pm 1/8$  inches ( $610 \pm 3$  mm).

## 8.5 Specimen Conditioning

8.5.1 The specimens will be conditioned at  $70^\circ \pm 5^\circ\text{F}$  ( $21^\circ \pm 2^\circ\text{C}$ ) and  $55\% \pm 10\%$  relative humidity for a minimum of 24 hours prior to testing.

## 8.6 Preparation of Apparatus

8.6.1 The air inlet of the oil burner must be completely sealed except for an opening where the air monitoring device will be placed. With the anemometer setup for measuring, turn the motor on and run it for at least 30 seconds to allow the blower to reach its operating speed (it is not necessary for the ignitor and fuel flow to be turned on). Set the airflow to  $67 \pm 4$  ft<sup>3</sup>/min ( $1.89 \pm 0.011$  m<sup>3</sup>/min) by adjusting the air

shutter (see paragraph 8.3.5.2 of Chapter 8 Supplement for airflow conversion). Once this airflow value is attained, keep the air shutter in position by tightening the lock screw. This will be the initial airflow setting. Later adjustments may be necessary to reach calibration temperatures and heat flux within the specified airflow range.

- 8.6.2 If a calibrated flow meter is not available, measure the fuel flow using a graduated cylinder of appropriate size. Turn on the fuel pump and the burner motor, making sure the igniter system is off. Collect the fuel by placing a plastic or rubber tube into the graduated cylinder for a 2-minute period. Ensure that the flow rate is  $2 \pm 0.1$  gal/hr ( $0.126 \pm 0.0063$  L/min).

## 8.7 Calibration

- 8.7.1 Secure the calorimeter in its bracket and place it on the specimen mounting test frame, making sure it is centered over the burner cone at a distance of  $8 \pm 1/8$  inches ( $203 \pm 3$  mm) from the exit of the burner cone, as shown in figure 8-5. Ensure that the burner is in the proper position relative to the specimen mounting frame,  $2 \pm 1/8$  inches ( $51 \pm 3$  mm) from the sidewall panel frame. Position the center of the calorimeter over the center of the burner cone.
- 8.7.2 Prior to starting the burner, ensure that the calorimeter face is free of soot deposits and that there is water running through the calorimeter.

**CAUTION!** Exposing the calorimeter to the burner flame without water running through it will destroy the calorimeter.

- 8.7.3 Rotate the burner from the test position to the warmup position. Examine and clean the burner cone of any evidence of buildup of products of combustion, soot, etc.
- 8.7.4 While the burner is in warmup position, turn on the fuel flow and light the burner. Allow it to warmup for at least 2 minutes. Move the burner into test position and adjust the air intake to produce a heat flux density of  $7.5$  Btu/(ft<sup>2</sup> second) ( $8.6$  W/cm<sup>2</sup>) or greater. Record the heat flux density measurements at least once per second averaged over a 30-second time period to ensure that steady-state conditions have been achieved. After steady-state conditions have been achieved, turn the burner off.
- 8.7.5 Replace the calorimeter bracket with the thermocouple rake. Check the distance of each of the seven thermocouples to ensure that they are located  $8 \pm 1/8$  inches ( $203 \pm 3$  mm) from the horizontal plane of the burner exit. Place the center thermocouple (thermocouple number 4) over the center of the burner cone exit (see figure 8-6).
- 8.7.6 Turn on the burner and allow it to warm up for at least 2 minutes. After warmup, record the temperature of the thermocouples at least once per second averaged over a 30-second time period. The temperature of each thermocouple will be  $1600^{\circ}\text{F}$  ( $871^{\circ}\text{C}$ ) or greater.
- 8.7.7 If the temperature of each thermocouple is not within the specified range, repeat sections 8.7.1 through 8.7.3 until all parameters are within the calibration range. When required thermocouple temperatures have been achieved, check that the airflow is within the required range. Once the parameters are within the specified range, secure the air shutter by tightening the lock screw.
- 8.7.8 Calibrate prior to each test until consistency (heat flux and temperature remaining within calibration tolerance) has been demonstrated. After consistency has been confirmed, several tests can be performed with calibration conducted before and after the tests. See this chapter's supplement for recommendations on achieving calibration.

## 8.8 Procedure

- 8.8.1 Examine and clean the cone of soot deposits and debris.
- 8.8.2 Mount the sidewall and/or ceiling cargo liner specimen(s) on the respective frame(s) and secure to the test frame(s) using the retaining frame(s). Bolt the retaining frame(s) and the test frame(s) together. Verify that the horizontal test frame is level.

- 8.8.3 Mount the thermocouple or thermocouple rake  $4 \pm 1/8$  inches ( $102 \pm 3$  mm) above the horizontal ceiling panel test specimen. If the thermocouple rake is being used, position the center thermocouple (thermocouple number 4) over the center of the burner cone exit.
- 8.8.4 Move the burner into warmup position so that the flame does not impinge on the test specimen during the warmup period. Turn on the burner and allow it to stabilize for at least 2 minutes.
- 8.8.5 Move the burner into test position, then start the timing device.
- 8.8.6 Record the temperature of the thermocouple (thermocouple number 4, if using the thermocouple rake also used for calibration) at least once a second for the duration of the test.
- 8.8.7 Expose the specimen to the flame for 5 minutes or until flame penetration occurs.
- 8.8.8 The following sections present testing procedures for patch repairs, seams, joints, fastening systems, lighting fixtures, and corners.
  - 8.8.8.1 Patch Repairs  
See Chapter 15 for instructions.
  - 8.8.8.2 Seams, Joints, Fastening Systems, Lighting Fixtures, and Corners  
The barrier material used for design features such as recessed lighting fixtures and pressure relief valves will be tested in the same manner as a cargo liner specimen. Seams, joints, and fasteners in the ceiling position will be tested longitudinally extending the length of the liner and centered over the burner cone. Seams or joints used on the sidewall will be positioned 2 inches from the top of the liner longitudinally as representative of the aircraft application. Apply the test procedures in sections 8.8.1 through 8.8.8 to test these design features.
- 8.8.9 Turn off the burner to terminate the test.

## 8.9 Report

- 8.9.1 Report a complete description of the material(s) being tested, including manufacturer, thickness, etc.
- 8.9.2 Report the orientation of the panels tested (i.e., ceiling and/or sidewall).
- 8.9.3 Record any observations regarding the behavior of the test specimen during flame exposure, such as delamination, resin ignition, smoke, etc., and the time each event occurred.
- 8.9.4 Report the time of occurrence of flame penetration, if applicable, for each of the three specimens tested.
- 8.9.5 If flame penetration does not occur, report the maximum backside temperature and time of occurrence.
- 8.9.6 Provide a record of calibration.

## 8.10 Requirements

- 8.10.1 None of the three specimens tested will burn through within the 5-minute flame exposure.
- 8.10.2 Each of the three specimens tested will not exceed 400°F at the backside temperature monitored during flame exposure.
- 8.10.3 Specimens that pass in the ceiling orientation may be used as a sidewall panel without further test.
- 8.10.4 For the patch adhesion test, the patch must be intact after the 5-minute flame exposure.



## Chapter 8 Supplement

This supplement contains advisory material pertinent to referenced paragraphs.

8.3.2 The basic burner and the use of tabs are described in FAA Powerplant Engineering Report No. 3A, "Standard Fire Test Apparatus and Procedure for Flexible Hose Assemblies," dated March 1978, and Report No. DOT/FAA/RD/76/213, "Re-evaluation of Burner Characteristics for Fire Resistant Tests," dated January 1977. The test settings specified in this specification, however, differ from those specified in the above reports.

8.3.2.1 A Monarch 80-degree AR or 80°R nozzle, nominally rated at 2.25 gal/hr (0.142 L/min) at 100 lb/in<sup>2</sup> (0.69 MPa) and operated at 85 lb/in<sup>2</sup> (0.59 MPa) gauge, has been found satisfactory to maintain a fuel flow of 2 gal/hr (0.126 L/min) and produce a proper spray pattern. A Monarch 80-degree CC nozzle, nominally rated at 2 gal/hr at 100 lb/in<sup>2</sup> and operated between 95 and 105 lb/in<sup>2</sup> gauge, is also acceptable. Minor deviations to the fuel nozzle spray angle, fuel pressure, or other parameters of the nozzle are acceptable if the fuel flow rate, flame temperature, and burner heat flux density conform to the requirements of section 8.6 of the handbook.

8.3.2.3 A fuel pressure regulator that is adjusted to deliver  $2 \pm 0.1$  gal/hr ( $0.126 \pm 0.0063$  L/min) flow through the nozzle should be provided. An operating fuel pressure of  $85 \pm 4$  psig ( $0.57 \pm 0.03$  MPa) for a 2.25 gal/hr (0.142 L/min) 80-degree spray angle nozzle has been found satisfactory.

8.3.2.4 Number 2 Grade diesel fuel, Jet A, or the international equivalent is the recommended fuel because it has been found to produce satisfactory results if the flow rate and inlet airflow conform to the requirements of sections 8.6 and 8.7 of the handbook.

8.3.4 The thermocouples are subjected to high temperatures durations during calibration. Because of this type of cycling, the thermocouples may degrade with time. Small but continuing decreases or extreme variations in temperature or "no" temperature reading at all are signs that the thermocouple or thermocouples are degrading or open circuits have occurred. In this case, the thermocouple or thermocouples should be replaced in order to maintain accuracy in calibrating the burner. It is recommended that a record be kept for the amount of time the thermocouples are exposed to the oil burner's flame.

8.3.5.2 The Omega microprocessor-based portable air velocity kit, model HH-30, is a recommended unit. The kit includes a vane-type air velocity sensor, hand-held digital readout displaying air velocity, extension rods, and a 9-volt lithium battery. Since the unit monitors air velocity in FPM or MPS  $\pm 1$  percent reading accuracy, necessary conversions must be made to attain airflow values. To do this, the area of the opening of the air sensor must be measured. Once the area is found, install the air velocity sensor at the oil burner inlet (see figure 8-7 for location). Following the procedures prescribed in section 8.6.1, this value should be multiplied by the air velocity reading. (The area of the air velocity sensor for the Omega model HH-30 is 0.037 ft<sup>2</sup> [0.0034 m<sup>2</sup>]. As an example, by maintaining an air velocity reading of 1800 ft/min using the Omega air sensor described above, an air flow of 67 ft<sup>3</sup>/min should be achieved.) If an air velocity sensor other than the Omega model HH-30 is being used, the same conversions apply.

$$\text{Airflow} = \text{Air Velocity} \times \text{Area of Opening (Air Velocity Sensor)}$$

8.6.1 An alternate method of airflow measurement involves removing the burner extension from the end of the draft tube. Turn on the blower portion of the burner without turning on the fuel or ignitors. Measure the air velocity using a hot-wire anemometer. Adjust the airflow using the damper so that the airflow is in the range of 1550 to 1800 ft/min (762 to 914 cm/second). (If tabs are being used, the tabs should be removed prior to measuring the airflow. After the measurement is complete, reinstall the tabs and the cone extension.)

### 8.7 Static Disks

Static disks were recently developed to stabilize the air before entering the combustion area. Two were designed by Park Oil Burner Manufacturing Company of Atlantic City, New Jersey. The Park Oil Burner disks are both made of steel. See figure 8-8 for details on the disks. Disks 1 and 2 are made for easy assembly, only requiring the removal of the draft tube and installation of the disk. Disk 3 was developed by CEAT, the French Ministry of Defense. The disk is made of a Nomex honeycomb material. CEAT uses two honeycomb disks positioned behind the stabilizer.

These disks are an optional feature and are used (any one or more of the three) to help produce a more full and even flame pattern. However, there is no guarantee of achieving calibration using a disk with all of the various makes and models of burners used throughout the industry.

8.7.3 A stainless steel wire brush is one possible cleaning tool. Soot buildup inside the burner cone can affect the flame characteristics and cause calibration difficulties. Since the burner cone may distort with time, dimensions will need to be checked periodically.

8.7.4 The airflow should be adjusted to produce the proper flame as well as the proper temperature and heat flux density. Two different flame profiles may yield the same temperature and heat flux density. The correct flame is generally 8 to 10 inches in length and orange-yellow in color.

8.7.8 Following are recommendations for achieving calibration temperatures and heat flux:

1. Set the stabilizer  $3.25 \pm 0.25$  inches from the end of the draft tube.
2. Rotate the ignitor to the 6 o'clock and 9 o'clock position (viewpoint: looking toward the stabilizer from the end of the draft tube).
3. Seal all possible air leaks around the burner cone and draft tube area.
4. Use static disk to improve flame characteristics.
5. Replace thermocouples after 50 hours of use.

8.8.8.2 Test procedures for cargo liner design features are described in FAA Technical Note DOT/FAA/CT-TN88/33, dated September 1988.

8.10.1 Flames that may appear on the side of the specimen away from the burner or as a result of the ignition of flammable smoke and/or gases produced from the specimen by the heat from the burner do not constitute burnthrough. Burnthrough occurs only if the flame from the burner passes through the specimen.

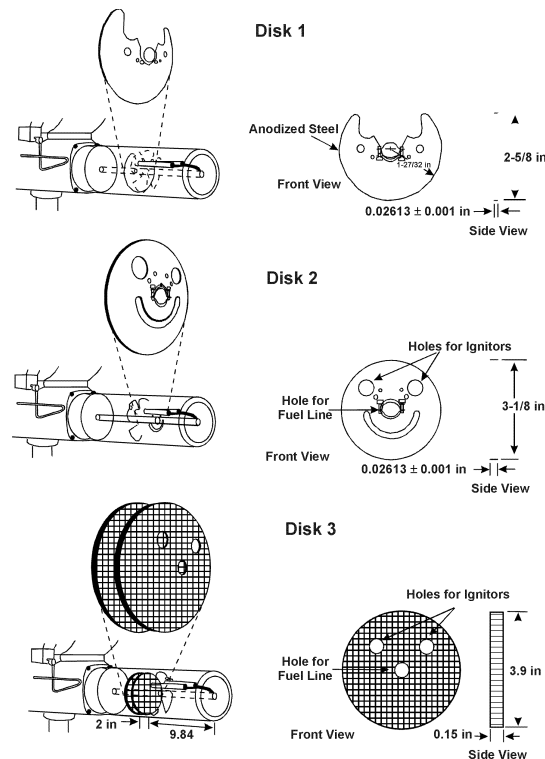

Figure 8-8. Static Disk Illustration