

# Waste Compartment Fire Containment MOCs



Scott Campbell

March 6, 2018

IAMFTWG- Savannah, GA

# Waste Compartment Fire Containment

14 CFR 25.853(h)

All Waste Compartments, Meal Trolleys & Waste Trolleys must be substantiated by Test or Analysis.

Industry/Regulators lack harmonized published methods of compliance (MOCs) to substantiate by analysis.

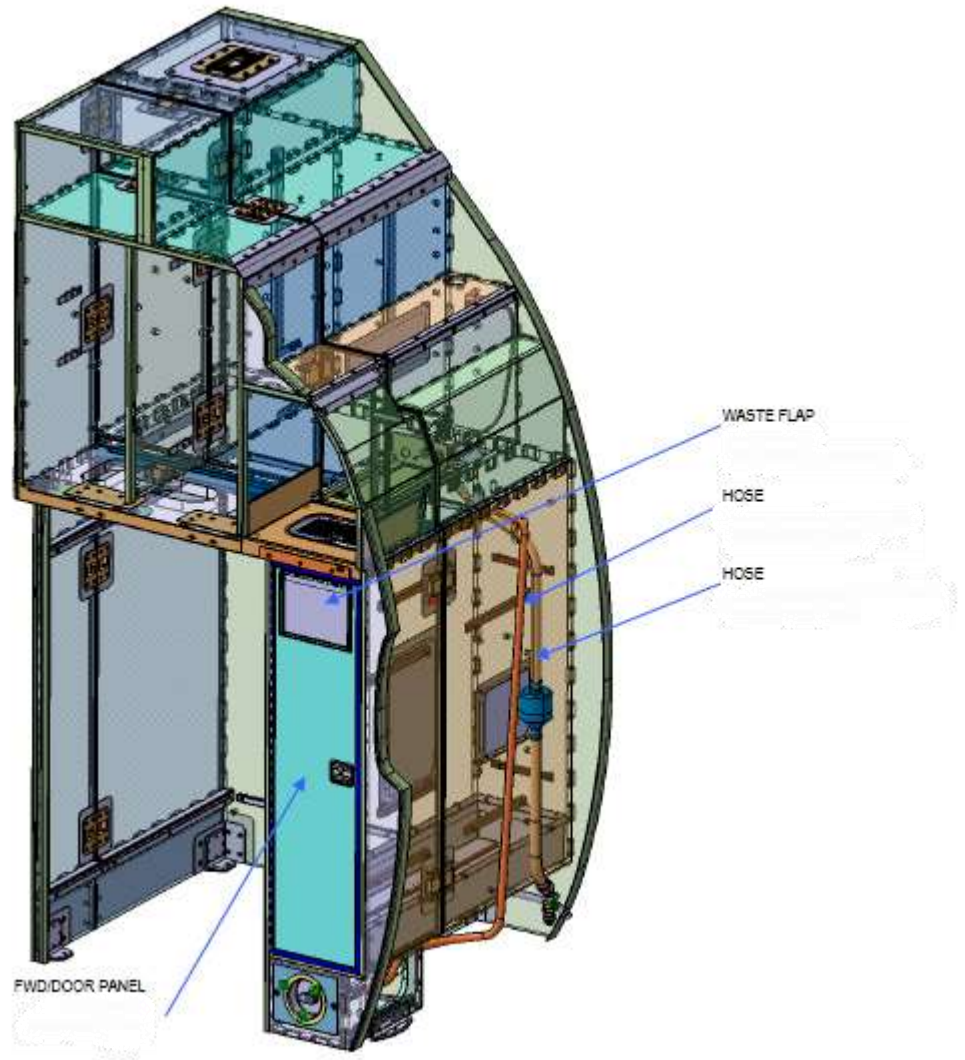

# Waste Compartment Fire Containment

Zodiac Aerospace has compiled approximately 15-17 MOCs accepted by various customers including our ODA.

Only a few of these are specifically mentioned in FAA ACs

The others are straight forward often using aspects of the flammability Policy Statement.



# Waste Compartment Fire Containment- A

## Few potential similarity examples:

Can thinner core panels tested substantiate thicker core panels (same materials) for the same application (sides ceilings, etc)?

Can Less skin plies tested substantiate more skin plies (same material) for the same application (sides, ceilings, etc)?

Can Nomex and Kevlar core be interchangeable and be able to substantiate panels skins with aluminum core?



# Waste Compartment Fire Containment- A

## Few potential similarity requirements:

Latch features: must have similar or greater engagement. Must be in a similar location and same quantity.

Ratio of air gap to volume must be less than tested.

Waste flap must be in the same location (installed on vertical vs. horizontal).

Etc.

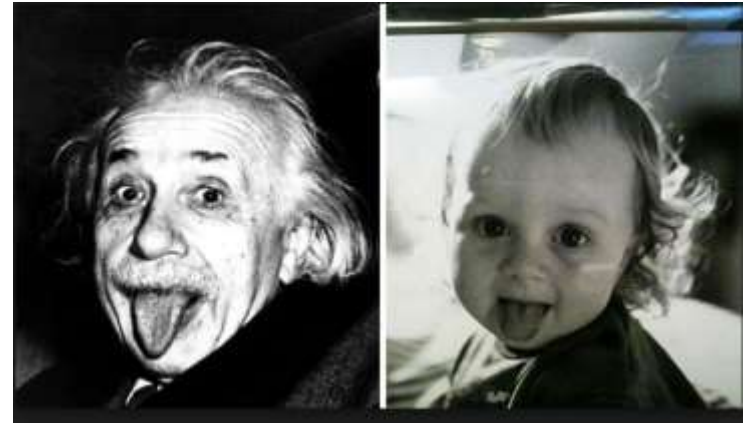

# Waste Compartment Fire Containment- And What about this brain teaser?

Air gap through hinges- Can we standardize an approach?

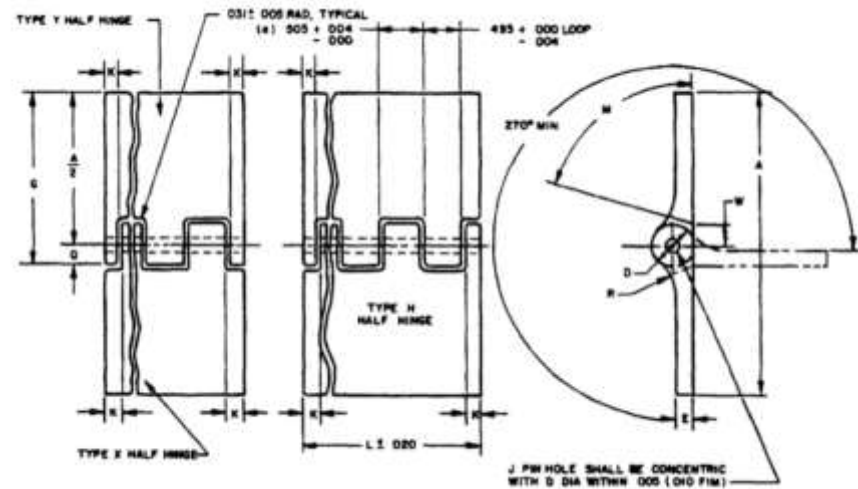
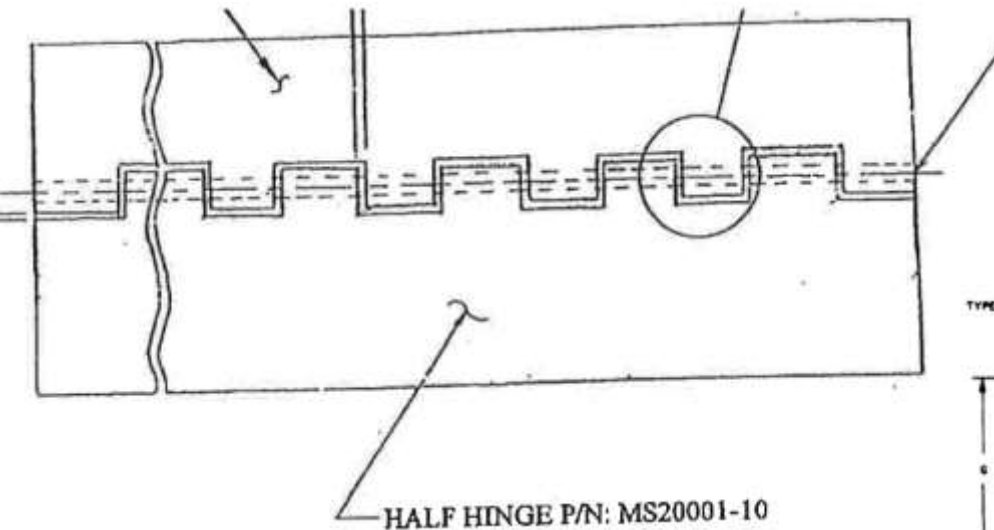

# Purpose of Proposed Task Group

Harmonize and publish industry and regulator accepted 25.853(h) Similarity requirements & MOCs for waste compartments and galley trolley carts.

Develop new MOCs as needed.

Discuss test set up and test parameters- harmonize as necessary.

